

Easy Installation

Rooftop Photovoltaics

Rooftop and Facade Photovoltaic Systems





The Megasol principle

Successful as a team

We managed to retain the start-up spirit: We are young, fast, and incredibly innovative. Today, we are Europe's most successful manufacturer of solar modules. In this context, our customers are the decisive factor because close cooperation and team efforts are what makes the difference for success. We know and appreciate each other. With many of our customers, we are on first-name terms, and lots of them have become our friends. We appreciate frank and open feedback. Many of our product innovations result from exactly suchlike feedback. Our doors and hearts are open to our clients – whether we meet on-site, have raclette together at our Deitingen headquarters or enjoy a drink at one of our tradeshow appearances.

These are our principles:

1

Close contact to our customers, partners and friends

- > Direct contact to all stakeholders
- > Support for layout, sales, and implementation/realisation
- > Installation plans, ballasting plans, string plans
- > Formalities (EIV, ESTI, EEA)
- > On-site installation coaching
- > System trainings, e.g. for inverters

2

Fast and powerful systems

- > Systems with few components that are smartly designed
- > In-house developments focused on short installation times and maximum performance

3

Everything from a single source

- > Solar modules, mounting structures, inverters, generator connection boxes, electric materials
- > Integration of storage solutions, energy management and charging infrastructure for e-mobility
- > Quick provision through our in-house logistics and processing centre
- > Turn-key delivery to the construction site

6 Efficiency

Properties

- HiR cell technology 7
- Glass-glass solar modules 8
- RearCon module technology 9

10 Framed Glass-Glass Modules

Properties

- > Best price-performance ratio
- > The most efficient cell layout for each application
- > U-frame
- > Swiss warranty
- > Ex stock Deitingen, CH

20 Frameless Glass-Glass Modules

Properties

- > Swiss Made
- > Highest longevity
- > High static load resistance
- > Frameless

30 Roof Connection

Structure

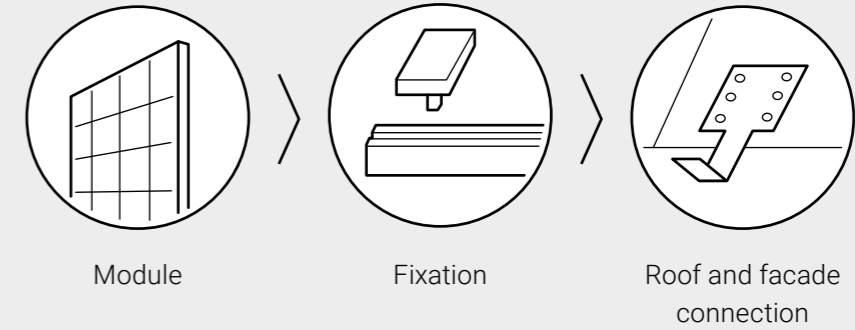

Module types

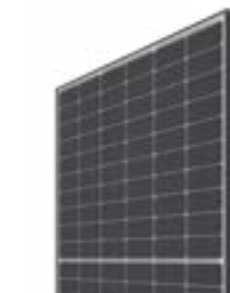

Mono HiR white U30b



RearCon Totally Black U30b

12

Fixation

- LOCKUP Fixation 14
- LOCKIN Inlaying system 18

Module types

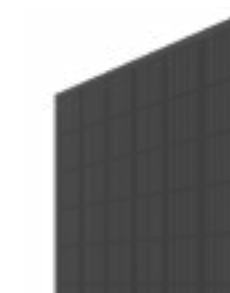

Mono HiR black GG3



Mono HiR translucent GG3

22

Fixation

- LAYUP Fixation 24
- LAYIN Inlaying system 28

Connecting to pitched roofs

30

Connecting to flat roofs

32

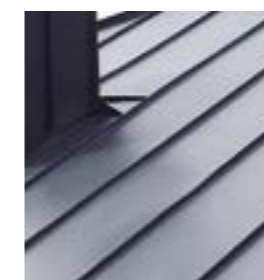

Seam metal roof



Classic tile



Flatport tray



HiR cell technology

Highest cell efficiency and lifetime thanks to 0% PID & LID

The new proprietary cell technology

HiR (pronounced like the word «higher») is a proprietary cell technology from Megasol. HiR is based on n-type wafers, which for decades have proven to be the highest quality and most stable technology. The n-type HiR technology combines charge carrier selective contacts, so-called ultra-thin tunnel oxides (SiO_2), with a sophisticated multi-stack metallization and a multi-level anti-reflective coating.

N-type HiR solar modules have a much higher power stability compared to conventional PERC modules. n-type HiR modules have a significantly lower power degradation and are completely PID- and LID-free due to their design.

In the market, PERC modules with 4-5% power degradation due to PID or LID are also considered «PID-free». However, a 4-5% difference in yield can have a massive impact on the economic profitability of solar plants.

Better economic profitability and higher project yields

- > n-type HiR modules have a very high power output combined with very compact dimensions. More yield per roof area leads to higher economic efficiency and better project yields.
- > An optimal thermal coefficient and better low-light performance lead to more yield per kWp.
- > All HiR modules are bifacial and have a significantly higher bifaciality factor compared to conventional bifacial solar modules (over 90% instead of 70-75%).
- > Considerably lower proportion of grey energy

How it works: simply explained

The ultra-thin tunnel oxide layer reduces recombination losses and thus significantly increases efficiency. The very fine front and rear contact grids guarantee ideal electrical current absorption capability with good solderability and conductivity thanks to their layers that have each been optimised for their respective characteristics. Thanks to the anti-reflective coating, which is not only classically single-layered but multi-layered, the reflection losses on the cell surface are minimised. At the same time, the cell surface appears darker (black), which makes it even more attractive for projects with high aesthetic requirements.

Longer service life and longer warranty periods

- > Glass-glass modules are extremely durable and come with a 15-year Swiss product warranty and a 30-year linear performance warranty.
- > Best wattage prices per warranty year

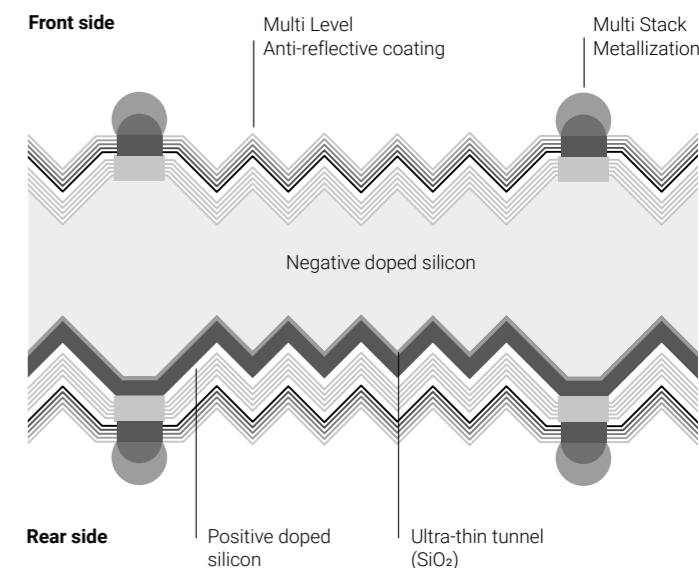

Glass-glass solar modules

Two glass panes are combined into one solar module. They become laminated safety glass and therefore have unique properties.

Areas of application

Applications include facades, railings, in-roof and on-roof applications, infrastructure structures (for example, dams, noise barriers, etc.), open spaces, carports, alpine and desert applications.

Properties

Front and back glass in combination with durable encapsulation material protect the components from vapour penetration. In the «neutral zone» between the panes, the cells remain stress-free (no compression or bending) which reduces the occurrence of so-called micro cracks. This results in a potential lifespan of over 50 years.

Freedom of design, high durability and stability characterize this solar building material.

Solar roof systems

Glass-glass solar modules can be laid with or without a frame. The mounting systems FAST, MATCH, LEVEL, NICER, LOCKUP, LOCKIN, LAYUP and LAYIN mounting systems are particularly suitable for integrating glass-glass solar modules

Non-glare solar glass

Particularly low-glare surface structures are used. The solar modules can be provided with the ZeroReflect design for complete freedom from glare.

Technical specifications

Megasol cell technologies: Mono HiR / Mono RearCon

Cell formats: 158.75 (G1 HiR), 166 x 83 (M6 Rearcon HC), 182 x 91 (M10 HiR HC) 210 x 105 (G12 HiR HC), 182 x 105 (G10 HiR HC)

Cell geometries: Full-square, Half-cut

Typical performance (Full Black)*: 184-232 Wp/m²

Typical performance (color)*: 150-210 Wp/ m²

Encapsulation material: PV encapsulant

Glass thicknesses per glass: 2 – 12 mm

Hail protection: Hail protection class 5 (grain size 50 mm)

Fire protection: B_{ROOF}(t1) in accordance with DIN EN 13501-5 (hard roofing, abP), the top cover layer and the rear side are made of heat-resistant glass. The construction is made of aluminum.

Tightness against driving rain: according to CEN/TR 15601

* The square meter output of the solar module depends on the specific format

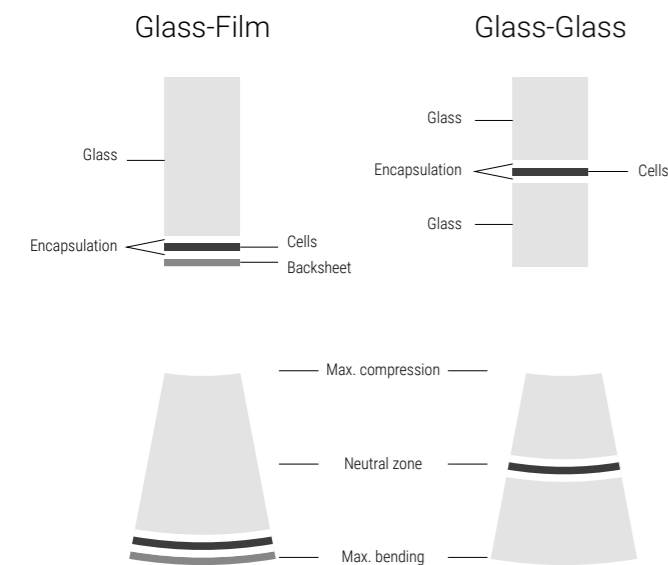
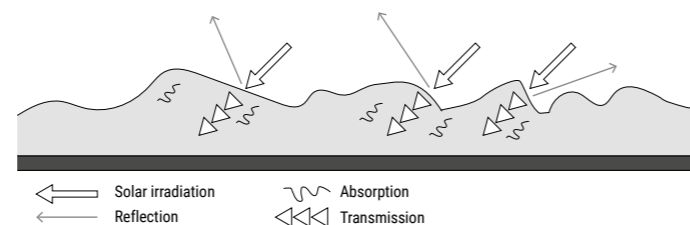

RearCon module technology

Elegant, deep black design, free of visible contacts, 23.2% cell efficiency – RearCon is a gamechanger.

Contacts on the rear side

RearCon means «Rear Contact». All contacting that was previously visible has been moved from the front to the back. This technology is a game changer in terms of performance, price, durability and aesthetics.

Three innovations for more performance

RearCon solar modules achieve module efficiencies of up to 23.2 %. RearCon's performance gains are achieved through the following technological innovations:

- > Dispensing with front contacting leads to more active cell surface and thus to higher efficiency.
- > Busbars with particularly high conductivity reduce internal resistance (lower ohmic losses).
- > Gapless modules: The cell bar spacing of - 0.3 mm (traditionally +2.0 mm) leads to space savings and higher efficiency.

Design and aesthetic integration

The innovations in the area of aesthetics include these key points:

- > The contacts on the front side («pinstripe look») are completely eliminated
- > RearCon modules have black, homogeneous «Totally Black» surfaces
- > The cells overlap slightly («gapless») – the classic «square structure» is avoided

Price superiority

Due to the technology, the production costs for RearCon are considerably lower. RearCon technology requires a significantly lower number of production steps than the production of previously known rear-contacted solar modules. This cost advantage is passed on. RearCon solar modules are therefore at a significantly lower price level than previous rear-contacted solar modules.

Solar modules without cell spacing

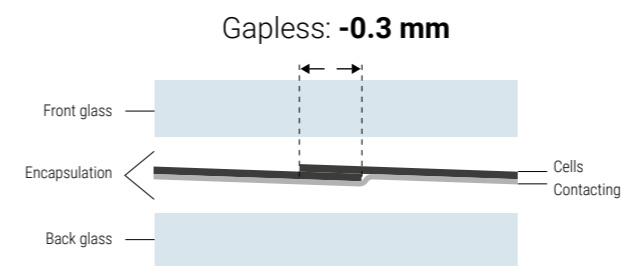

Solar modules with cell spacing

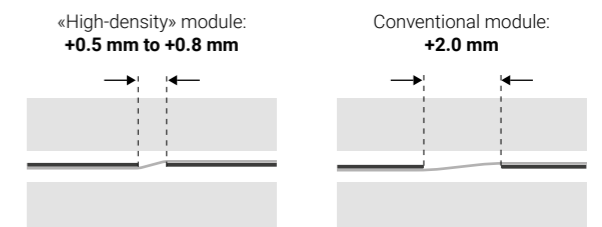

High performance modules

Quick to install, budget-friendly, and highly profitable: our framed high performance modules are extraordinarily durable «workaholics».

Low investment

- > Best market prices
- > Project prices on request



Latest technology

- > Highest efficiency levels (HiR & HiR RearCon)
- > Nano-coated solar glass
- > Optimized low-light performance

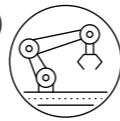

Wide product range

- > Power classes
- > Optics (Totally Black, Full Black, white)

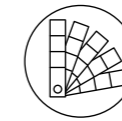

Environmentally friendly

- > Made with renewable power
- > Energetic amortisation under 2 years
- > Seamless traceability of all materials

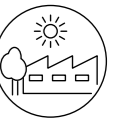

Secure fixation

- > LOCKUP module fixation
- > Compact dimensions
- > Low weight thanks to thin glass (2 x 2 mm)

20

Wide range of applications

- > The most efficient cell layout for each application
- > Bifacial glass-glass

Swiss warranty

- > 30 years linear performance warranty
- > 15 years product warranty
- > Produced at the Megasol plant in Ningbo

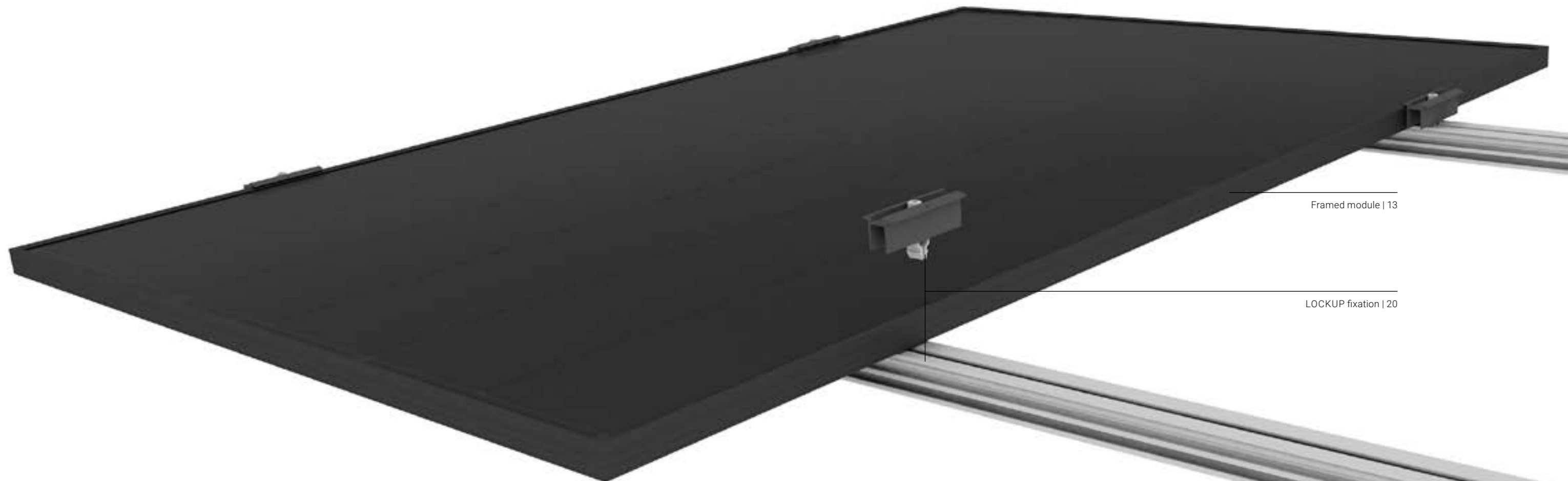

Framed module | 13

LOCKUP fixation | 20

Module types

Technical specifications

Laminate structure: Glass-glass

Megasol Cell technologies: Mono HiR / Mono HiR RearCon

Cell size: 158.75 (G1 HiR), 166 x 83 (M6 Rearcon HC), 182 x 91 (M10 HiR HC), 210 x 105 (G12 HiR HC)

Cell geometry: Full-square / Half-cut / Triple-cut

Frame: U-frame, aluminium, anodized natural or black

Front side: 2 mm TVG, high-transmission, nano-finished, antireflective

Back side: 2 mm TVG

Swiss warranty

Product warranty: 15 years

Linear performance warranty: 30 years

Suitable mounting systems

- > LOCKUP Fixation 14
- > LOCKIN Inlaying system 18

Bifacial: power from reflections

- > Double sided active cells
- > Additional yields depend on the installation situation and the albedo (reflectivity) of the substrate

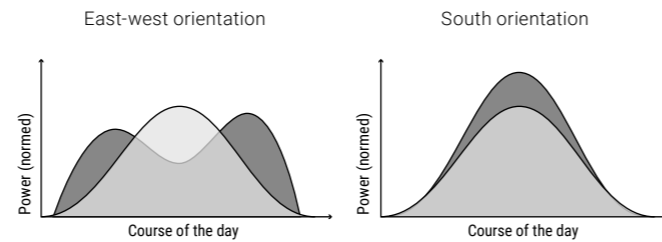

In east-west orientations, the rear produces most when the sun is flat. South facing bifacial plants generate their additional yield classically during the midday hours.

Potential bifacial gain

Low reflecting surface (e.g. grass, brick)	5-15%
Well reflecting surface (e.g. sand, bright gravel or paint)	15-25%
Highly reflecting surface (e.g. ice, snow)	25-35%

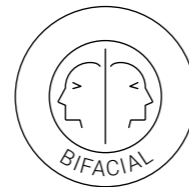

Framed Glass-Glass Modules



HiR RearCon Bifacial M6 HC120 | Totally Black

Cell type: RearCon M6 (166 mm)
Matrix: 120 half-cut cells
Frame: U30 black
Cell spacing color: black (partial printing)

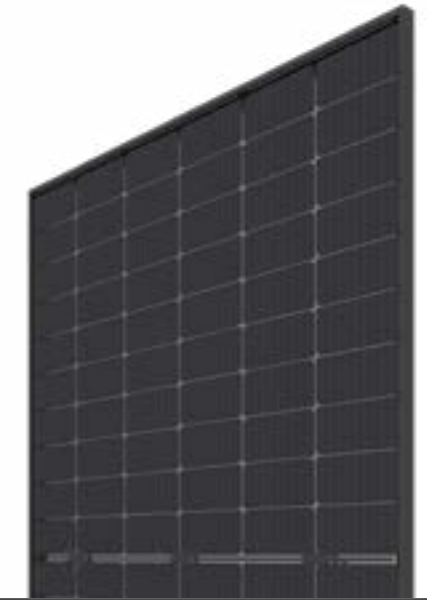

Mono HiR Bifacial M6 HC120 | Full Black optics

Cell type: n-type HiR M6 (166 mm)
Matrix: 120 half-cut cells
Frame: U30 black
Cell spacing color: translucent

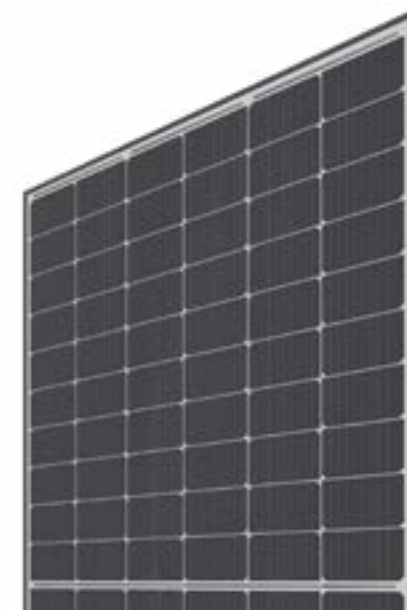

Mono HiR Bifacial M6 HC120 | White

Cell type: n-type HiR M6 (166 mm)
Matrix: 120 half-cut cells
Frame: U30 black
Cell spacing color: white (partial printing)

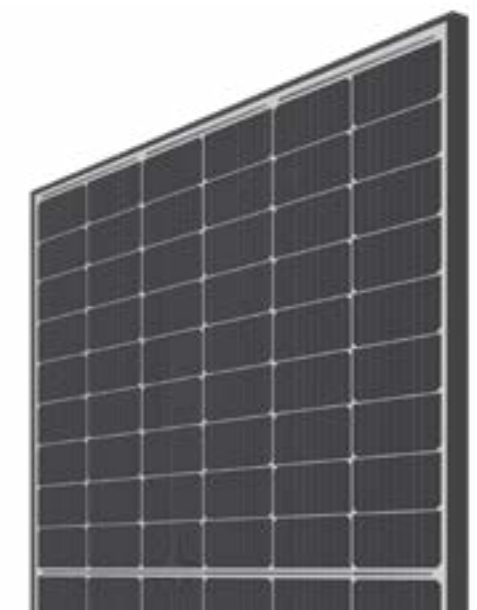

Mono HiR Bifacial M10 HC108 | White

Cell type: n-type HiR M10 (182 mm)
Matrix: 108 half-cut cells
Frame: U30 black
Cell spacing color: white (partial printing)

LOCKUP module fixation

The fixation system for framed modules that is fully compatible with components of leading manufacturers.

Two components

- > Rail
- > Clamp

Simple connection

- > Fastening to roof connection by means of screws or cross connectors

Secure fixation

- > Click in the clamp
- > Tighten with screwdriver

High compatibility

- > All frames 30-40 mm
- > Pitched roof and flat roof
- > Compatible with all roof connections from Megasol, Schletter and K2

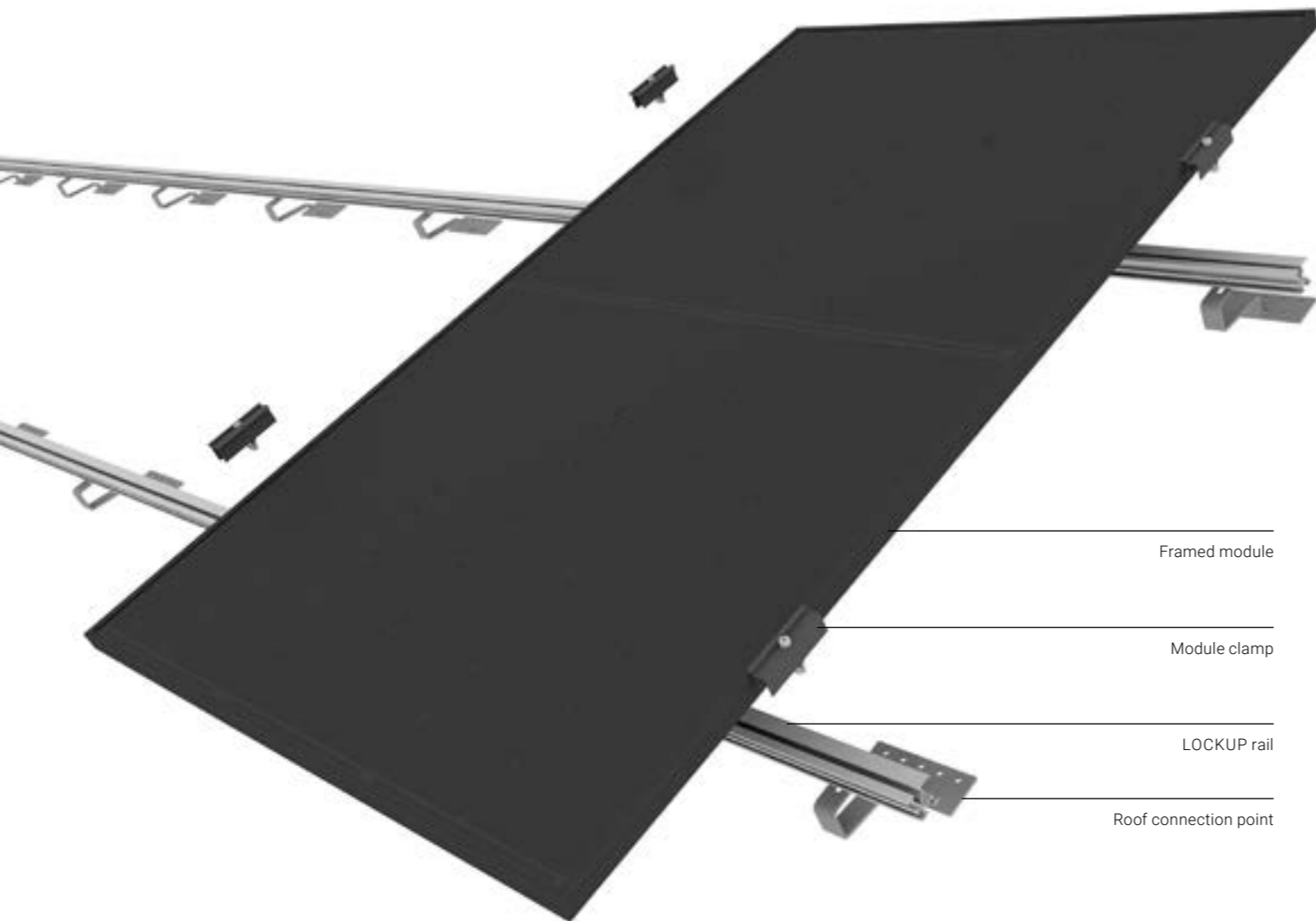

LOCKUP Roof: Pitched roof fixation

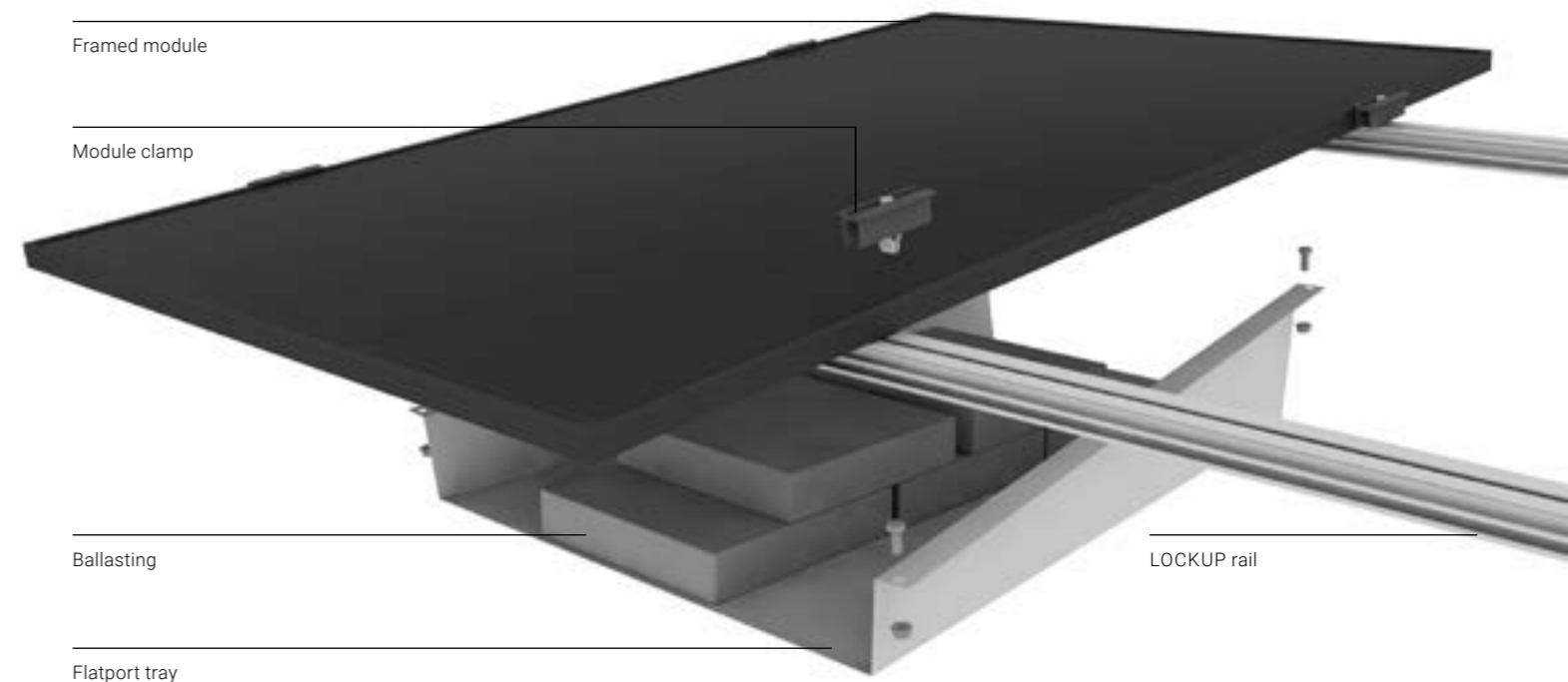

LOCKUP Flatport: Flat roof fixation

LOCKUP components

Rails



3337.0330
LOCKUP rail 6650 mm



3337.0331
LOCKUP connector

Clamps



3231.0212
Module middle clamp
Rapid16, 30-40 mm
black



3231.0217
Module end clamp
Rapid16, 30-40 mm
black



3231.0128
Rapid cross connector

Order now directly at store.megasol.ch



LOCKIN inlaying system

The inlaying system for facades and roofs for framed modules with full compatibility with the components of the leading manufacturers.

Two components

- > Rail
- > Locking plate

Safe inlaying system

- > Insert module diagonally upwards
- > Place vertically and lower
- > Mount end plate
- > No further fixing necessary

Simple Connection

- > Direct connection by means of sheet metal adapter
- > Alternatively: fastening to other facade and roof connections by means of cross connectors or screws

High compatibility

- > Facade, pitched roof and flat roof
- > Compatible with all facade and roof connections from Megasol, Schletter and K2
- > Framed modules (30 mm frame)

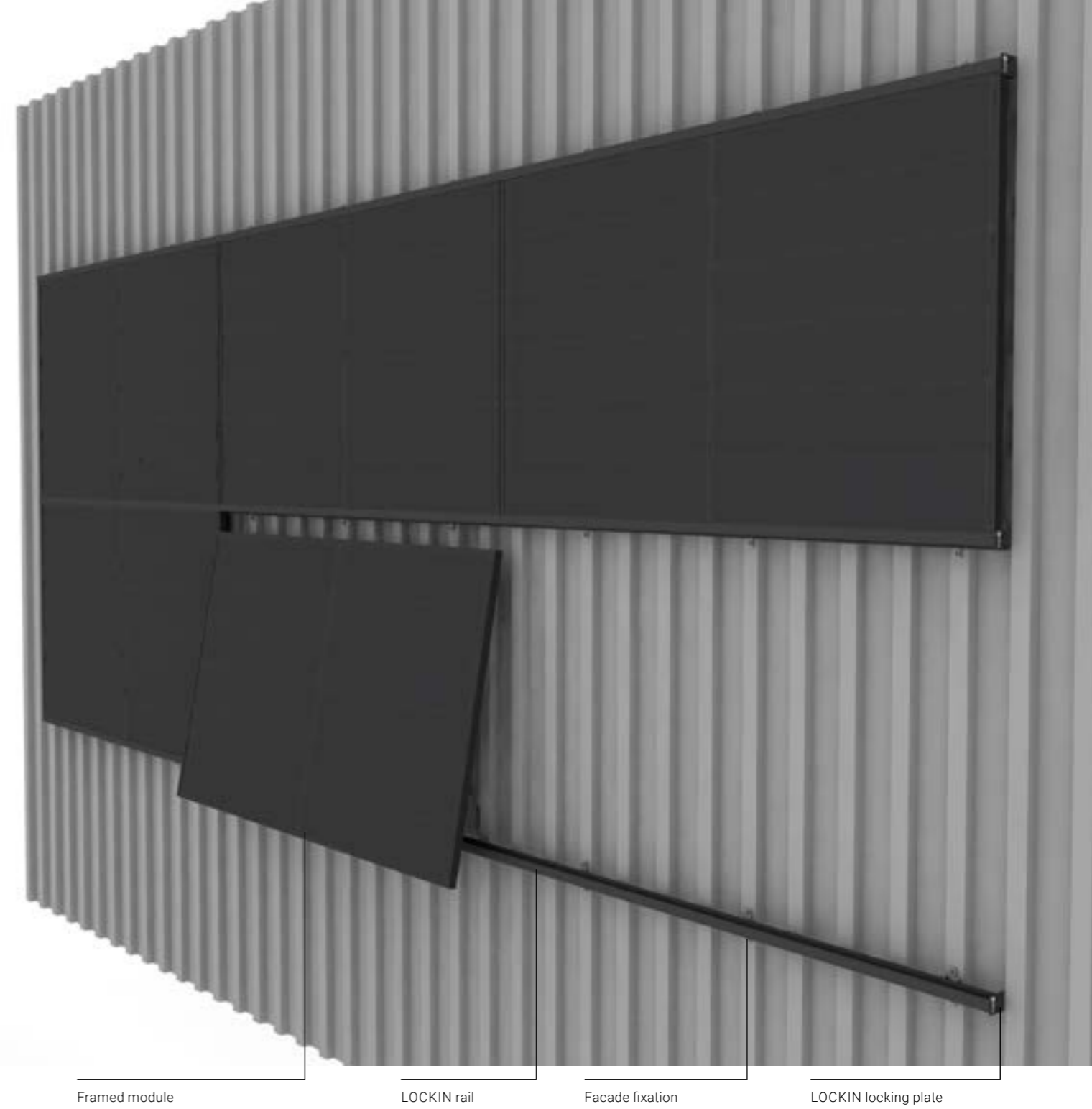

Components

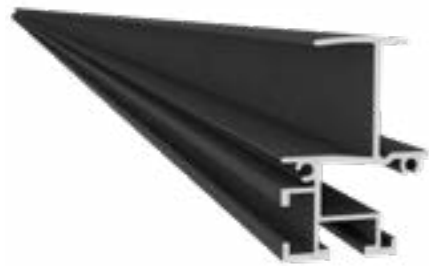

3337.0846
LOCKIN rail U30 5325mm



3337.0869
LOCKIN locking plate kit



3337.0871
LOCKIN/LAYIN connector



3337.0345
Sheet adapter kit



Detail: locking plate

Swiss Premium modules

With a potential lifespan of over 50 years our Swiss Made glass-glass solar modules are particularly interesting for institutional investors.

Swiss quality

- > 35 years linear performance warranty
- > 15 years product warranty
- > Made in Deitingen, Switzerland



Profitable investments

- > Service life of more than 50 years
- > Highest yields
- > Lowest watt price per warranty year



Sustainable production

- > Made with renewable power sources
- > Energetic amortisation under 2 years
- > Seamless traceability of all materials

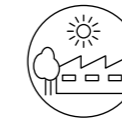

Wide range of applications

- > Cell technologies
- > Power classes
- > Optics

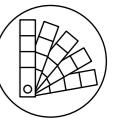

Frameless glass-glass module | 20

LAYUP fixation | 24



Module types

Frameless Swiss Premium modules

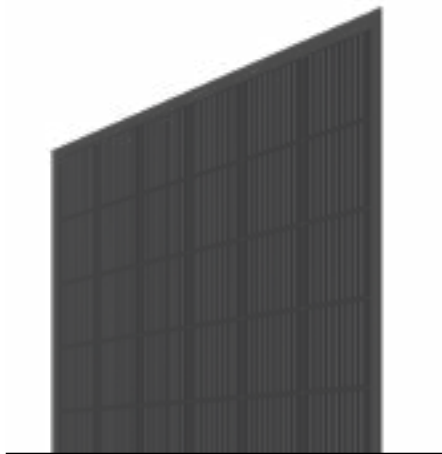

Swiss Premium GG3 | Black
2x 3.2mm solar glass
Frameless

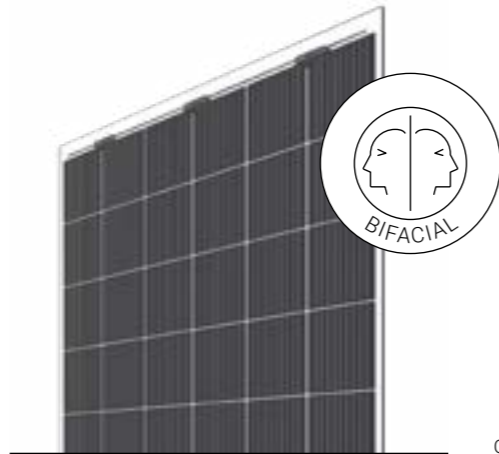

Swiss Premium GG3 | Translucent
2x 3.2mm solar glass
Frameless

Order now directly at store.megasol.ch

Technical specifications

Laminate structure: Glass-glass

Megasol Cell technologies: Mono HiR / Mono HiR RearCon

Cell formats: 158.75 (G1 HiR), 166 x 83 (M6 Rearcon HC), 182 x 91 (M10 HiR HC) 210 x 105 (G12 HiR HC), 182 x 105 (G10 HiR HC)

Cell geometry: Full-square / Half-cut

Frame: Frameless

Encapsulation material: PV encapsulant

Glass thickness per pane: 2 - 12 mm

Hail protection: Protection class 5 (hailstone size 50 mm)

Fire protection: $B_{ROF}(t1)$ in accordance with DIN EN 13501-5 (hard roofing, abP), the top cover layer and the rear side are made of heat-resistant glass. The construction is made of aluminum.

Suitable mounting systems

- > LAYUP Fixation 24
- > LAYIN Inlaying system 28

Bifacial: power from reflections

- > Double sided active cells
- > Additional yields depend on the installation situation and the albedo (reflectivity) of the substrate

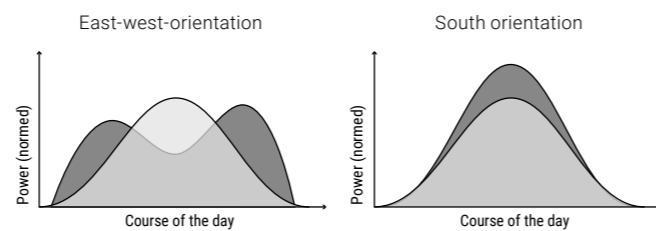

In east-west orientations, the rear produces most when the sun is flat. South facing bifacial plants generate their additional yield classically during the midday hours.

Potential bifacial gain

Low reflecting surface (e.g. grass, brick)	5-15%
Well reflecting surface (e.g. sand, bright gravel or paint)	15-25%
Highly reflecting surface (e.g. ice, snow)	25-35%



▲ Vortex Campus in Lausanne | High-performance modules with LOCKUP Flatport | 330 kWp | Image: Université de Lausanne

LAYUP fixation

The mounting system for frameless glass-glass modules (monofacial or bifacial) that is fully compatible with components of leading manufacturers.

Versatile application

- > Monofacial or bifacial glass-glass modules
- > Pitched roof, flat roof and facade
- > Compatible with all roof connection points from Megasol, Schletter and K2

Elegant look

- > Flush-mounted installation
- > Without protruding frames (CleanFrame effect)

Three components

- > LAYUP rail (black / classic aluminium)
- > LAYUP clamps (black / classic aluminium)
- > Cross connector or screw

Secure fixation

- > Connection with screws or cross connectors
- > Placed on the rail and secured with clamps
- > High stability thanks to large contact surface

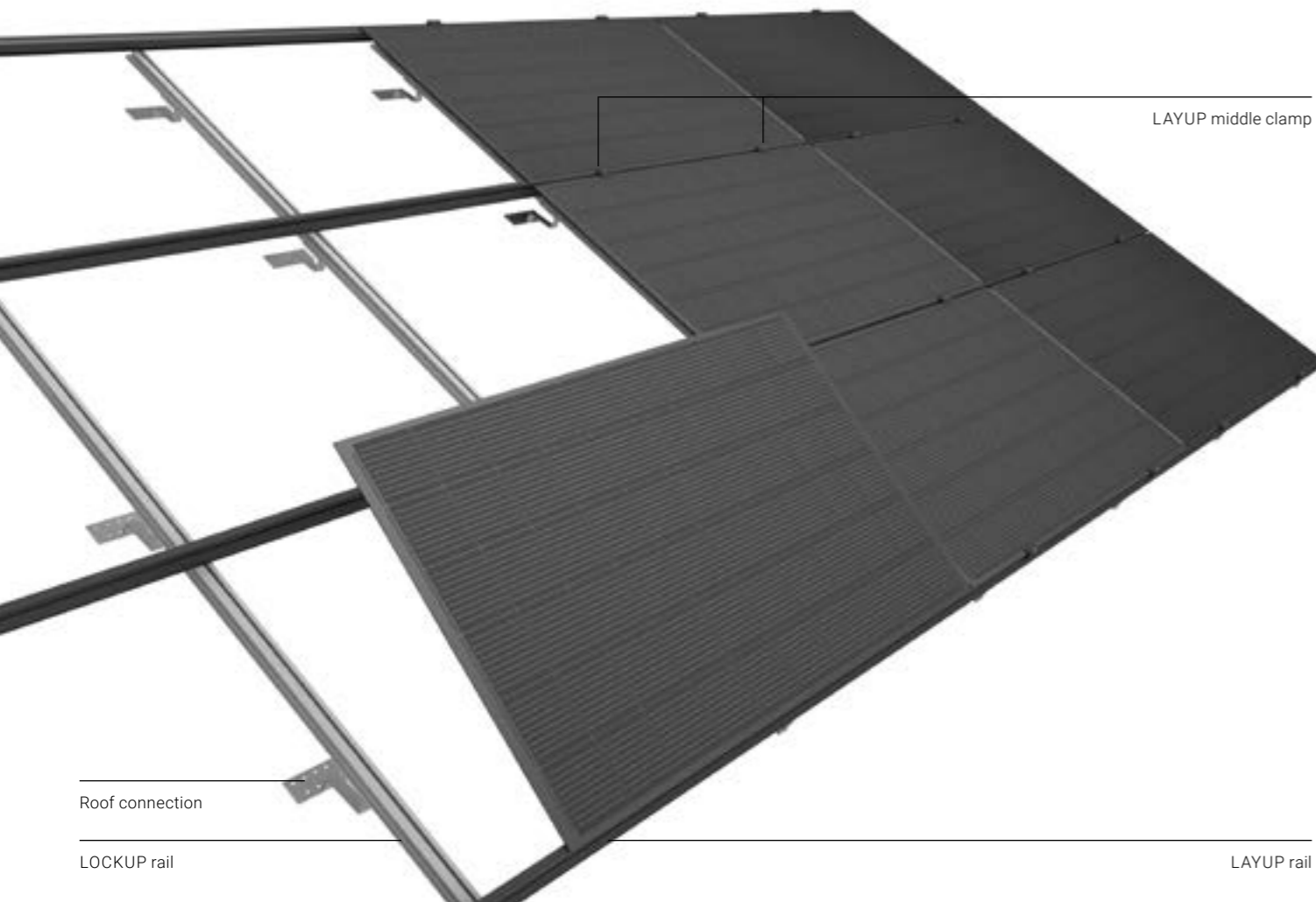

LAYUP Roof: Fixation on pitched roofs

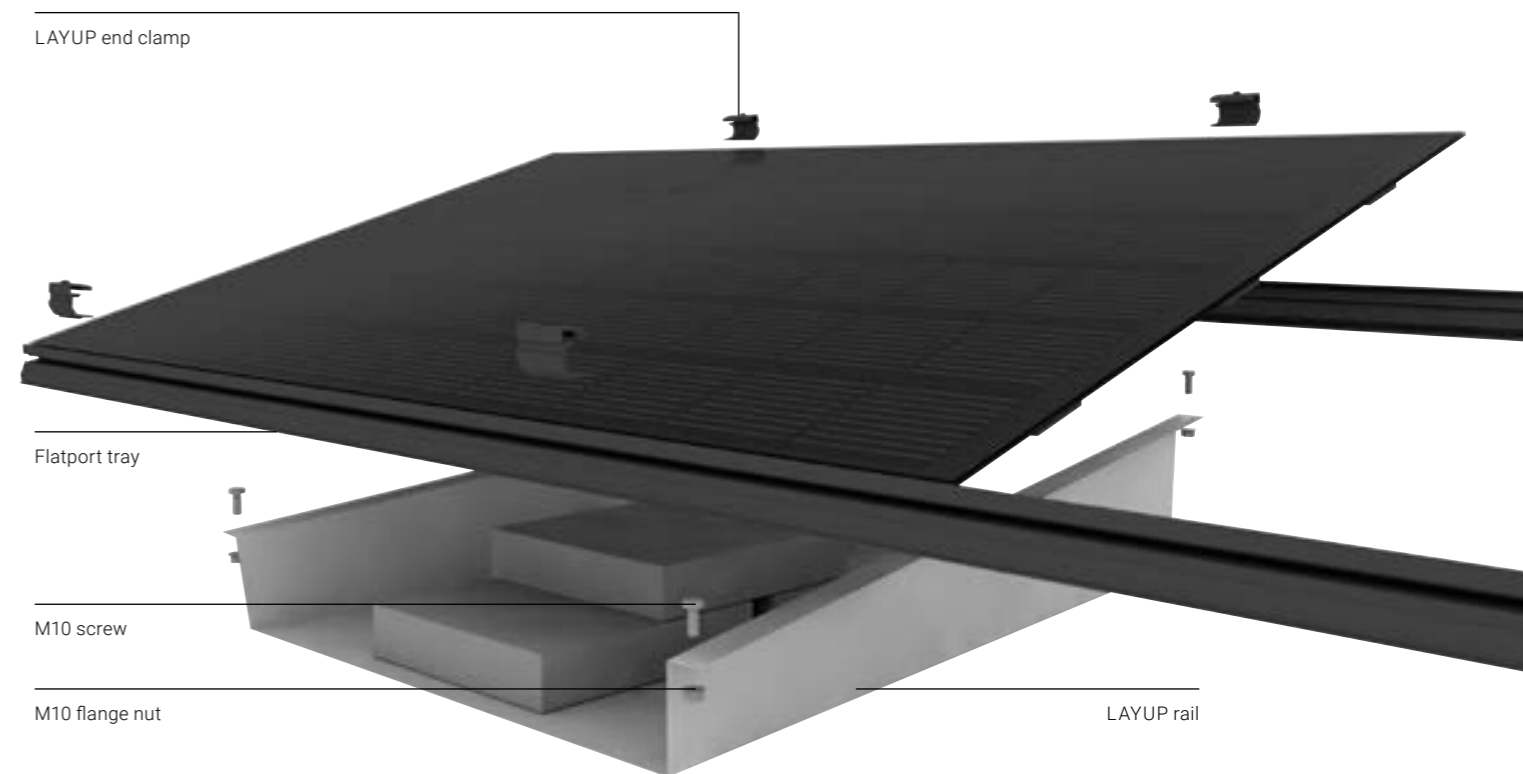
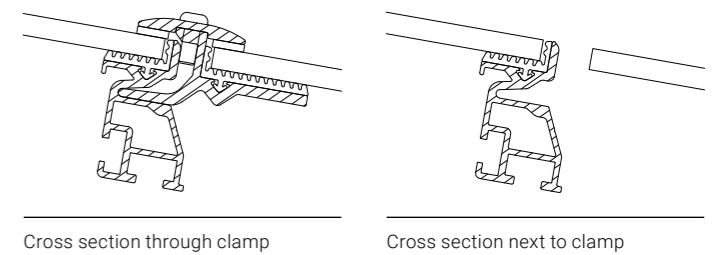

LAYUP Flatport: Flat roof fixation

LAYUP components

Rails

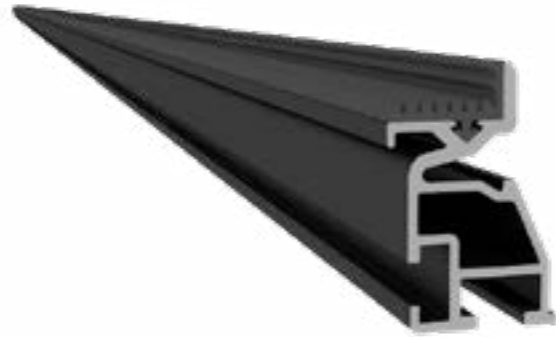

3337.0318
LAYUP rail 6700 mm black



3337.0310
LAYUP rail connector
kit with screws

Clamps



3337.0308
LAYUP middle clamp
kit black



3337.0301
LAYUP end clamp
black



LAYIN Inlaying system

The inlaying system for facades and roofs for frameless modules with full compatibility with the components of the leading manufacturers.

Two components

- > Rail
- > Locking plate

Simple Connection

- > Direct connection by means of sheet metal adapter
- > Alternatively: fastening to other facade and roof connections by means of cross connectors or screws

Safe inlaying system

- > Insert module diagonally upwards
- > Place vertically and lower
- > Mount end plate
- > No further fixing necessary

High compatibility

- > Facade, pitched roof and flat roof
- > Compatible with all facade and roof connections from Megasol, Schletter and K2
- > Frameless modules

Components



3337.0853
LAYIN rail GG 5900mm



3337.0870
LAYIN locking plate kit



3337.0871
LOCKIN/LAYIN Connector



3337.0345
Sheet adapter kit

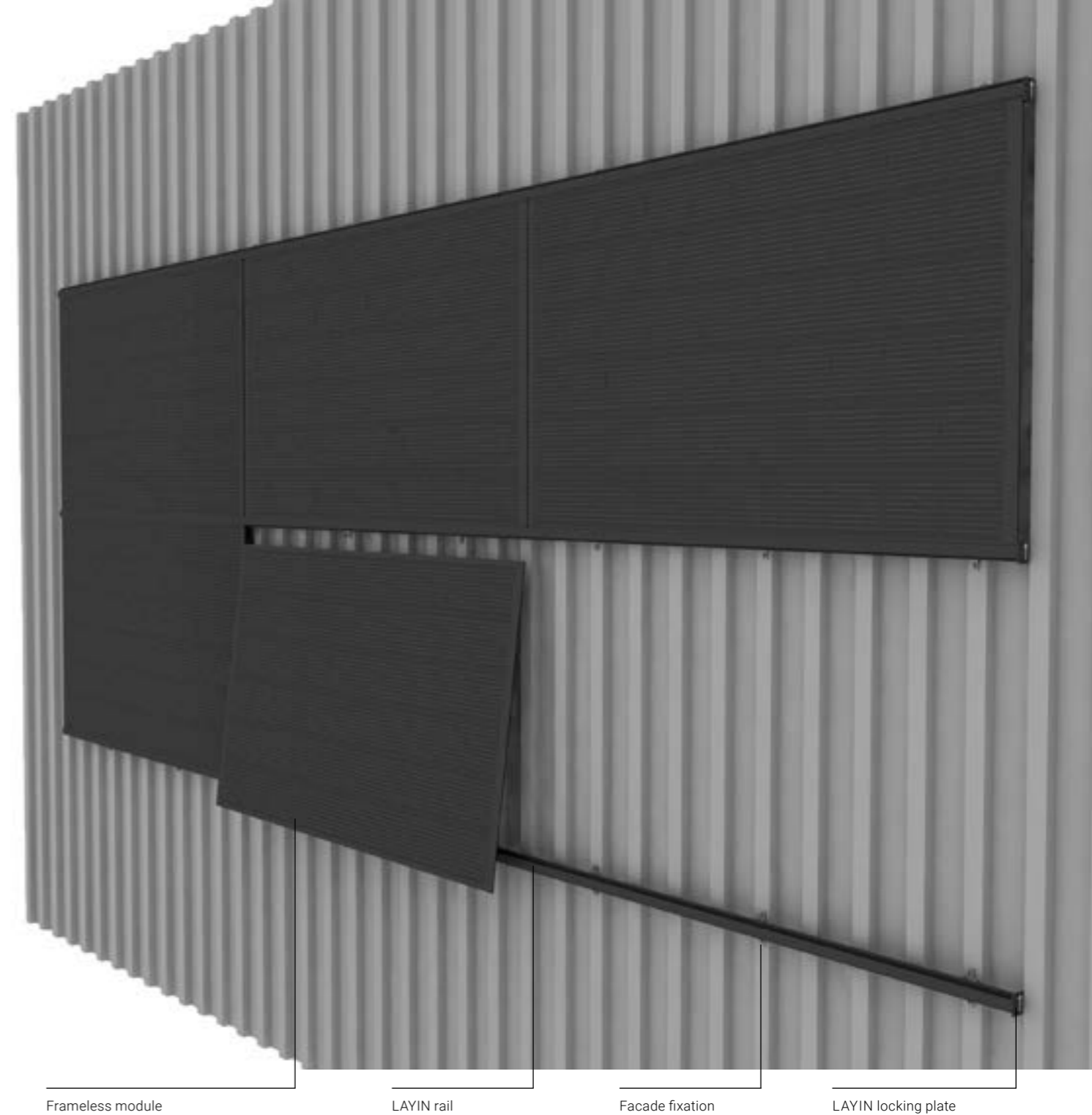

Detail: Locking plate

Connecting to pitched roofs

The well-elaborate connection points for pitched roofs can be perfectly combined with LOCKUP, LOCKIN, LAYUP and LAYIN module fixations.

Wide range of applications

- > The right solution for every roof covering
- > For different static load requirements

Simple combination

- > Compatible with LOCKUP, LOCKIN, LAYUP and LAYIN module fixations
- > Cross connectors or screws

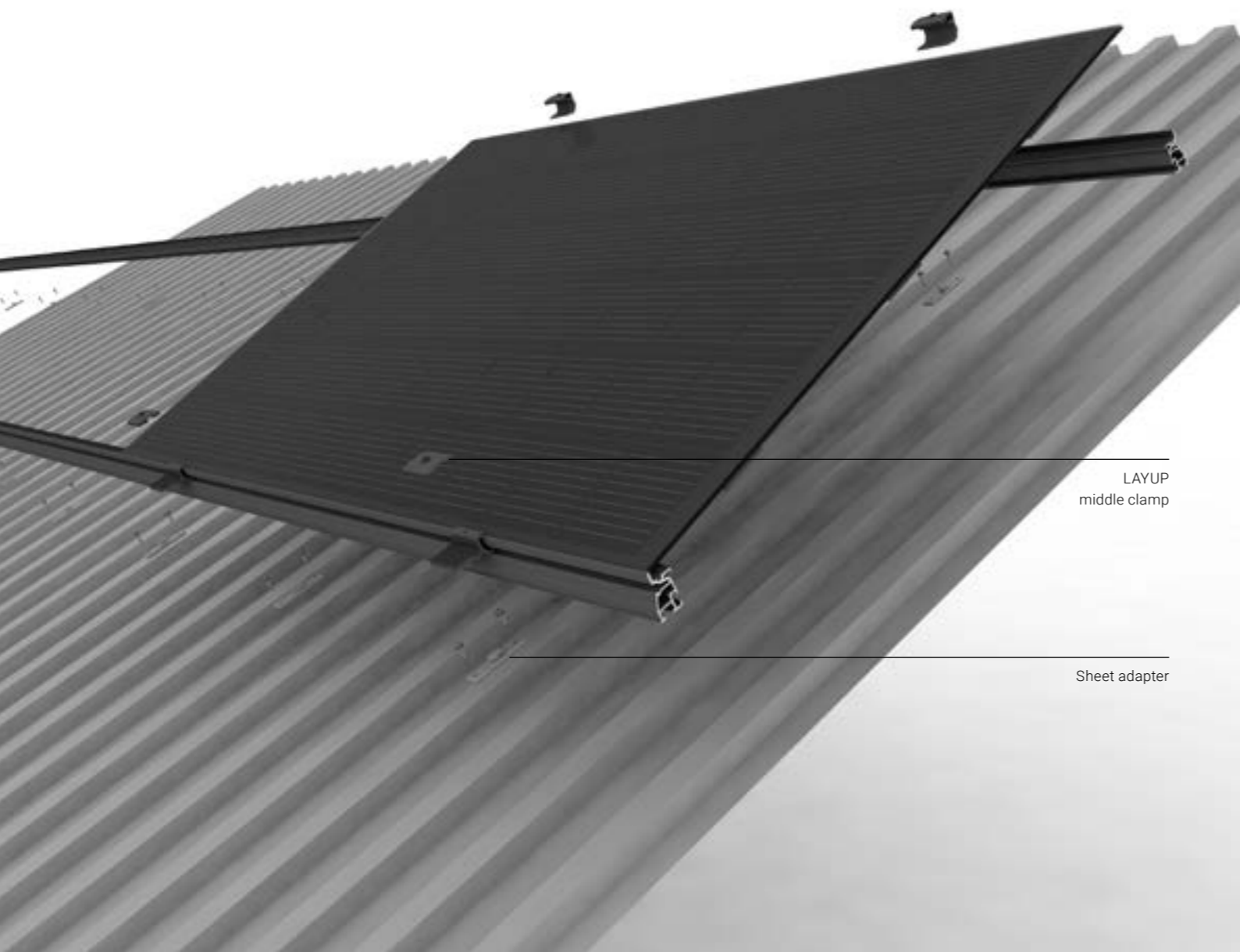

LAYUP
middle clamp

Sheet adapter

Components



Classic tile



3231.0038
Roof hook Rapid2+ ProMaxV



Seam metal



3333.0046
Clamp 504 AL KK for seam metal



Trapezoidal sheet



3337.0345
Sheet metal adapter kit



Corrugated roof



3231.0179
Fixation kit for corrugated roof
M12x300 KlickTop

Connecting to flat roofs

The easy-to-mount *Flatport* trays for flat roofs are the ideal base for LOCKUP and LAYUP module fixations.

Quick and gentle installation

- > Upside-down procedure
- > No punctual load on the roof membrane

Simple ballasting

- > Gravel or slabs
- > Ballasting plan on request

All flat roof coverings

- > Gravel / granulate
- > Vegetated / bitumen

High longevity

- > Corrosion resistant alloy
- > 10 years material warranty

Simple combination

- > Compatible with LOCKUP and LAYUP module fixations
- > Quick fastening with screws

Components



3339.0027
Optifix Flatport Adv. 6° 999&1040
10L



3231.0130
Hexagon screw M10x25



3231.0040 Flange nut M10
with locking teeth



1 Place the LOCKUP rail on Megasol trestles and insert M10x25 hexagon screws into the rail.



2 Place the Flatport trays upside down on the rails and tighten them with M10 flange nuts.

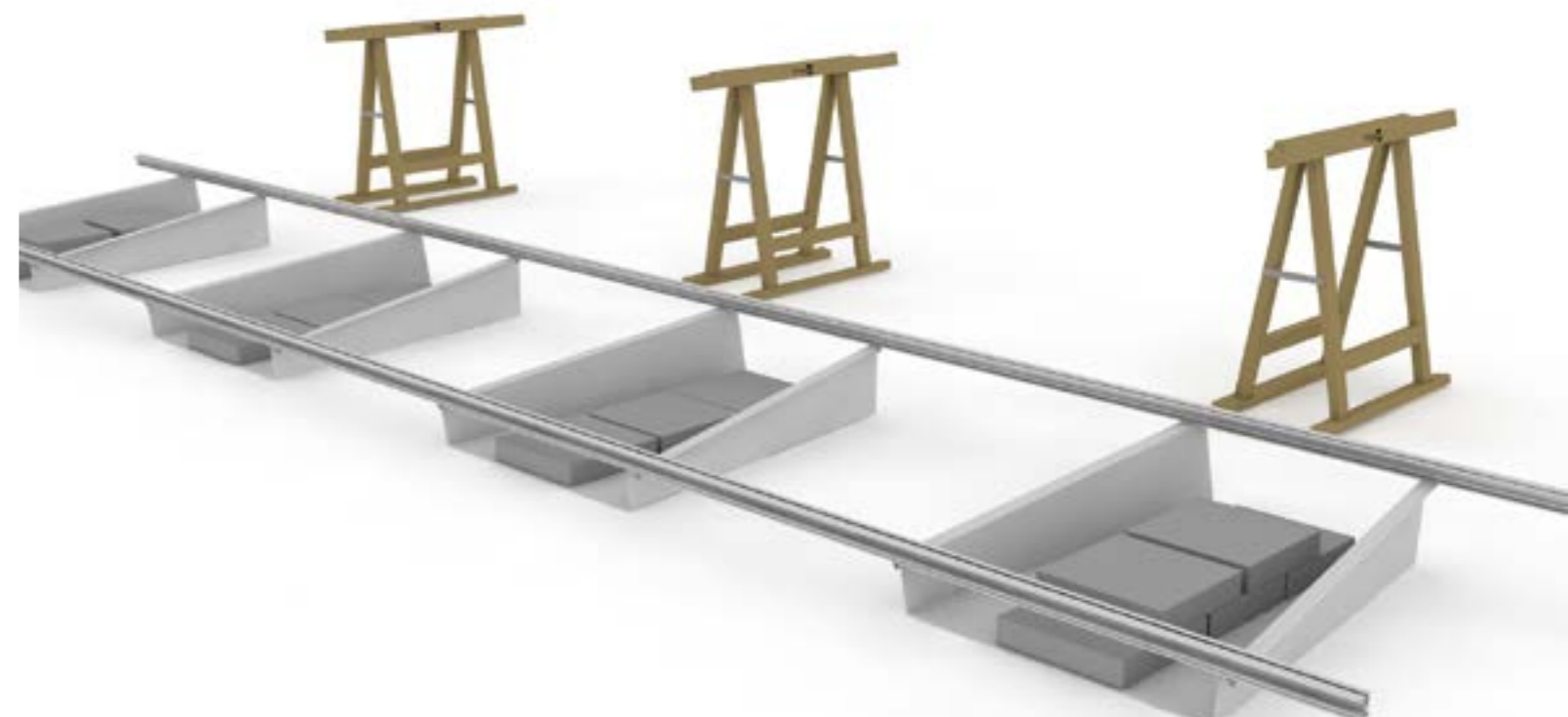

3 Turn the trays over with the rails, align them on the surface and ballast them.

Made in Deitingen



Development

We are committed to technological leadership in the field of all-in-one systems. Following this principle, we continuously drive the development forward. Megasol solar modules and mounting systems as well as our production processes are constantly analyzed and optimized. Our engineers, programmers and electrotechnicians closely cooperate to design and develop new products and the processes required to manufacture them.

Our test and research centre in Deitingen, Switzerland pools the entire expertise from planners and installers and shapes the development and advancement of new and existing products.

Optimizing performance

The nano-coated antireflective solar glass used for all products conducts the maximum amount of sunlight to the solar cells. Thanks to state-of-the-art spectral optimization, Megasol solar modules perform up to 15% better than customary modules under cloudy conditions and during dusk or dawn.

Certifications

The manufacturing processes are TÜV-tested and run in accordance with EN/IEC and ANSI/UL standards.

In-house test centre

Especially in high alpine environments, extreme heat or cold and the impact of snow and wind are particularly challenging for solar modules. The standard IEC test procedures do not account for these conditions.

Our test procedures are different – they exceed industry standards by far. An example: The IEC requires damp heat test procedures to cover 1'000 hours. Megasol increases this value by a factor of 10 to 10'000 hours.

At our Deitingen production site, we test: Damp-heat, shock freeze, UV lifetime, dynamic load, Overpressure and thermal cycle. Only top-quality materials that pass all tests without reservation are used to produce Megasol modules.

In-line testing

One production line is designed for medium-sized series, while the other is used to manufacture modules in a customer-specific design. Starting with precise controls of all semi-finished products, each step in the manufacturing process is subject to several controls.

Electroluminescence tests (3 times) as well as technical and optical controls accompany the entire manufacturing process up to the final flash test.

Cooperation with Saint-Gobain

Saint-Gobain, the world's largest manufacturer of building materials, invests in Megasol and holds a minority stake in the company. As part of the global distribution partnership with Saint-Gobain, Megasol is present in 76 countries.



Traceability

All data from production can be viewed electronically at any time. This also includes information on the materials used, which can be traced back seamlessly to the raw material batch. Our high-performance solar cells consist of high-purity silicon – free of cadmium, rare earths and heavy metals.

Recycling

Our commitment with the Swiss foundation SENS and the European PV Cycle enables the reuse of almost 100% of the used material.

Top Brand PV

Every year, the market research institute EUPD Research identifies the most successful and strongest brands on the PV market. For the installers surveyed, Megasol ranks consistently among the most popular module manufacturers.

Megasol is an award-winning company. Many Swiss and European solar prizes and architecture and design awards testify to the trust placed in Megasol.

Services

Project support:

- > Consulting / training
- > Detailed design options
- > Grid layout
- > Connection details / interfaces
- > String / inverter dimensioning
- > After Sales

Formalities:

- > EIV, ESTI, EEA

Development:

- > Design / colour
- > Samples / mock-ups
- > Customized mounting solutions
- > Integration of storage solutions, energy management, charging infrastructure for e-mobility

Megasol Energy Ltd.

Industriestrasse 3
CH-4543 Deitingen

+41 62 919 90 90
info@megasol.ch
www.megasol.ch
store.megasol.ch

© Megasol Energy Ltd.

ROOFTOP-EN-V9

Subject to errors and technical modifications

Rooftop Photovoltaics

Leading Architecture
Integrated Photovoltaics



WingPort
The smart Carport



SOLARCOLOR
Solar module design



▲ Brochures
online

▲ All brochures are available in DE, EN, FR, IT.

▼ Cleantech Businesspark in Deitingen

