

- |                            |                             |
|----------------------------|-----------------------------|
| 1 LEVEL module             | 6 LEVEL Support plate short |
| 2 LEVEL middle hook        | 7 Roof battens 80x40        |
| 3 LEVEL rail hook          | 8 Roof battens 50x50        |
| 4 LEVEL rail               | 9 junction box              |
| 5 LEVEL Support plate long |                             |

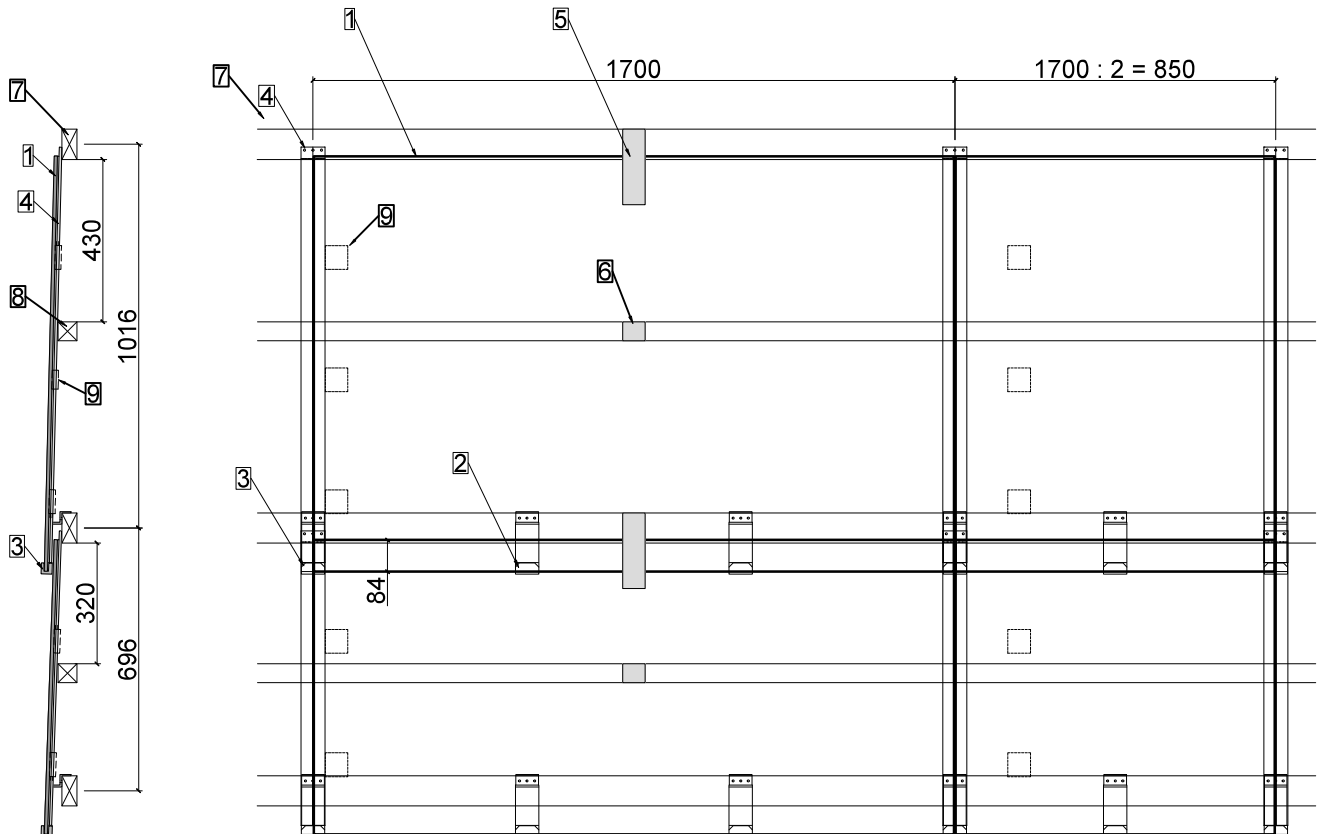

### Standard grid dimension horizontal

The horizontal grid dimension is fixed at 1700 mm (resp. 850 mm). Module edge to module edge is therefore 5 mm, rubber lip in between is 3 mm, leaving a margin of 1 mm per module side. This grid dimension can be extended up to 1710 mm (resp. 860 mm).

### Standard grid dimension vertical

The vertical grid dimension is fixed at 1016 mm. This grid dimension can be reduced to 1000 mm or extended to 1050 mm depending on the project. We do not recommend reducing the grid dimension of 696 mm. Extension to 730 mm is possible. In case of a reduction, please note that depending on the roof orientation, the shadow cast by the hooks may affect the cells. When extending, please note that the modules overlap less and that wider battens are required depending on the design.

### LEVEL modules left & right

In the standard modules, the junction boxes are mounted on the left side when viewed from the front. This must be taken into account during planning if an overhanging verge is planned, as well as for ridges and valleys. The junction boxes can be mounted on the right side on request.

### Wind and snow loads

The layout shown (planning notes and grid dimensions (1)) meets the requirements of IEC 61215. To meet increased requirements, more middle hooks and support plates can be mounted. See also "LEVEL layout for increased requirements". Statics and professional execution are always the responsibility of the contractor.

### Requirement for the subroof and recommendation of rear ventilation (counterbattens in mm)

Roof pitch 3° to 5 < 800 m a.s.l.   > 800 m a.s.l.		Roof pitch 6° to 13 < 800 m a.s.l.   > 800 m a.s.l.		Roof pitch from 14° to 25 < 800 m a.s.l.   > 800 m a.s.l.		Roof pitch from 25 < 800 m a.s.l.   > 800 m a.s.l.		Rafter length
Subroof in Flat roof quality		Subroof for extraordinary exposure		Subroof for increased exposure		Subroof for normal exposure		
80	80	80	80	80	80	80	80	<5 m
80	100	80	100	80	100	80	80	5-8 m
100	120	100	120	100	120	80	100	8-15 m
120	140	120	140	120	140	80	120	>15 m

### Aeration and ventilation opening

The free cross-section of the ventilation openings must correspond to half of the ventilation space (height of counterbattens). Reduction by perforated plate must be taken into account. In the case of roof penetrations, a constructive measure is required for detour.

### Offer plan layout

The modules are laid out in grid dimensions in the quotation plans. The roof line refers to the outer edge of the counterbattens for the eaves and ridge, and to the outer edge of the roof battens for the verge.

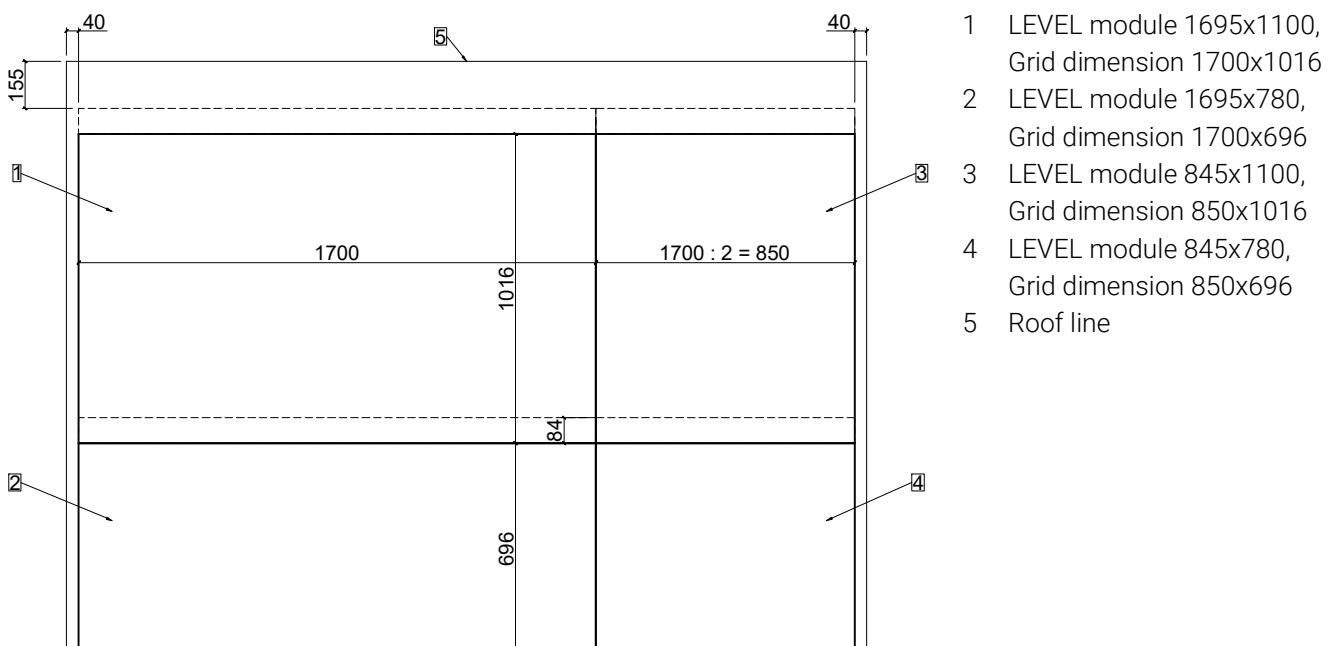

- 1 LEVEL module 1695x1100, Grid dimension 1700x1016
- 2 LEVEL module 1695x780, Grid dimension 1700x696
- 3 LEVEL module 845x1100, Grid dimension 850x1016
- 4 LEVEL module 845x780, Grid dimension 850x696
- 5 Roof line

Application recommendation for wind suction forces < 3.5 kN/m<sup>2</sup>, Snow load < 3.5 kN/m<sup>2</sup>

### Basic article with standard finish

Rail verge left & right

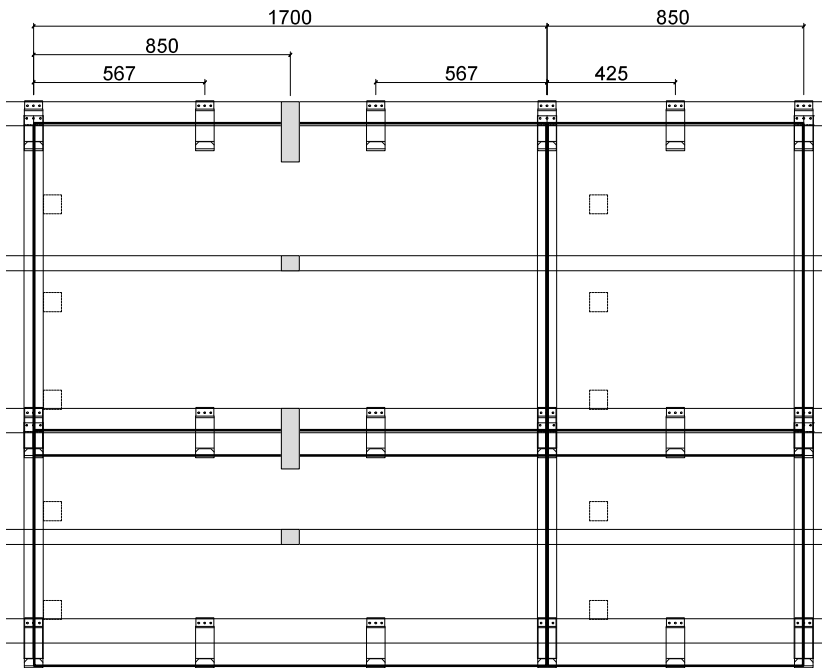

- 1 Rail/module plus
- 1 Rail/row end (Verge)
- 1 Rail hook/rail
- 2 Middle hooks/1695mm module  
resp. 1 Middle hooks/845mm module
- 1 Support plate short and 1 support  
plate long/1695mm module

### Ridge finish with middle hooks

- Additional 3 middle hooks/1695mm  
module in the top row resp. 2 middle  
hooks/845mm module in the top row  
plus 1 middle hook row end (verge)

### Basic article with overhanging verge

No rail verge left & right

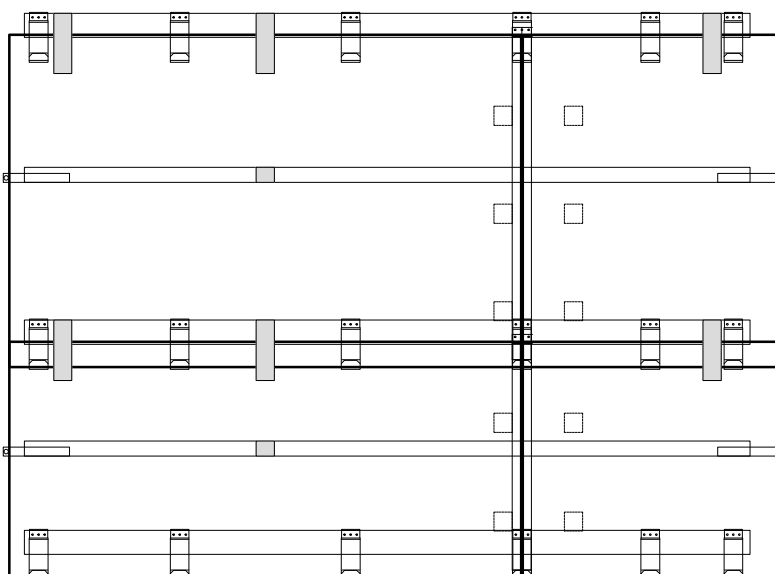

- 1 Rail/module minus
- 1 Rail/row end (verge)
- 1 Rail hook/rail
- 2 middle hook/1695mm module  
resp. 1 middle hook/845mm module
- 1 Support plate short and 1 support  
plate long/1695mm module plus 1  
support plate long/row end (verge)
- 1 Side support/row end (verge)
- 1 Middle hook/row end (verge)

### Ridge finish with middle hooks

- Additional 3 middle hooks/1695mm  
module in the top row resp. 2 middle  
hooks/845mm module in the top  
row plus 1 middle hook/end of row  
(verge)

## Increased claims

Wind suction 3.5 - 4.7 kN/m<sup>2</sup>, Snow load 3.5 - 8 kN/m<sup>2</sup>

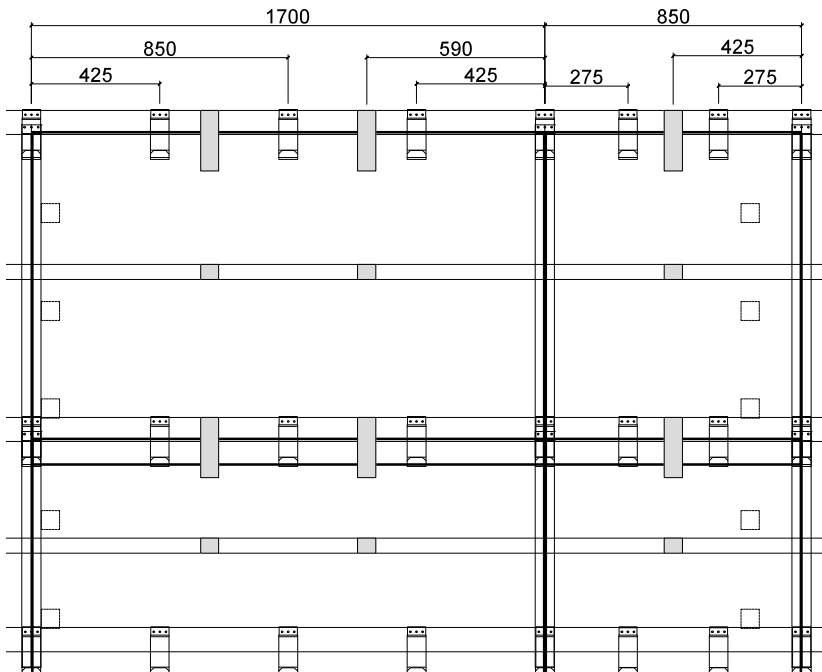

### Rail & middle hooks

- 3 Middle hooks/1695x1100mm module
- 3 Middle hooks/1695x780mm module
- 2 Middle hooks/845x1100mm module
- 2 Middle hooks/845x780mm module

### Support plates

- 2 Support plates short and 2 support plates long/1695x1100mm module
- 2 Support plates short and 2 support plates long/1695x780mm module
- 1 Support plate short and 1 support plate long/845x1100mm module
- 1 Support plate short and 1 support plate long/845x780mm module

## Extraordinary claims

Wind suction 4.7 - 5.9 kN/m<sup>2</sup>, Snow load 8 - 13 kN/m<sup>2</sup>

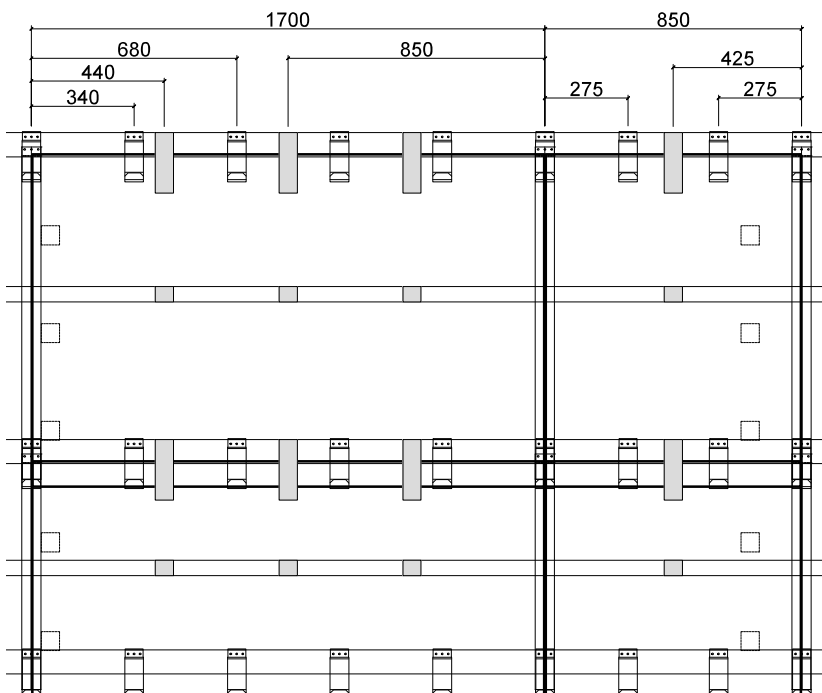

### Rail & middle hooks

- 4 Middle hooks/1695x1100mm module
- 4 Middle hooks/1695x780mm module
- 2 Middle hooks/845x1100mm module
- 2 Middle hooks/845x780mm module

### Support plates

- 3 Support plates short and 3 support plates long/1695x1100mm module
- 3 Support plates short and 3 support plates long/1695x780mm module
- 1 Support plate short and 1 support plate long/845x1100mm module
- 1 Support plate short and 1 support plate long/845x780mm module

For wind suction forces > 5.9 kN/m<sup>2</sup> or snow loads > 13 kN/m<sup>2</sup> we recommend mounting 4x10-cell modules instead of 6x10-cell modules. All data (kN/m<sup>2</sup>) are load limits without safety factors. The static of the entire roof structure is the responsibility of the contractor.

## Rails and roof battens

| A4 | 1:5 | V23.01 |

- 1 LEVEL module 1695x1100
- 2 LEVEL module 1695x780
- 3 LEVEL rail hook
- 4 LEVEL rail 1100
- 5 LEVEL rail 780
- 6 Roof battens 80x40
- 7 Roof battens 50x50
- 8 Counterbattens

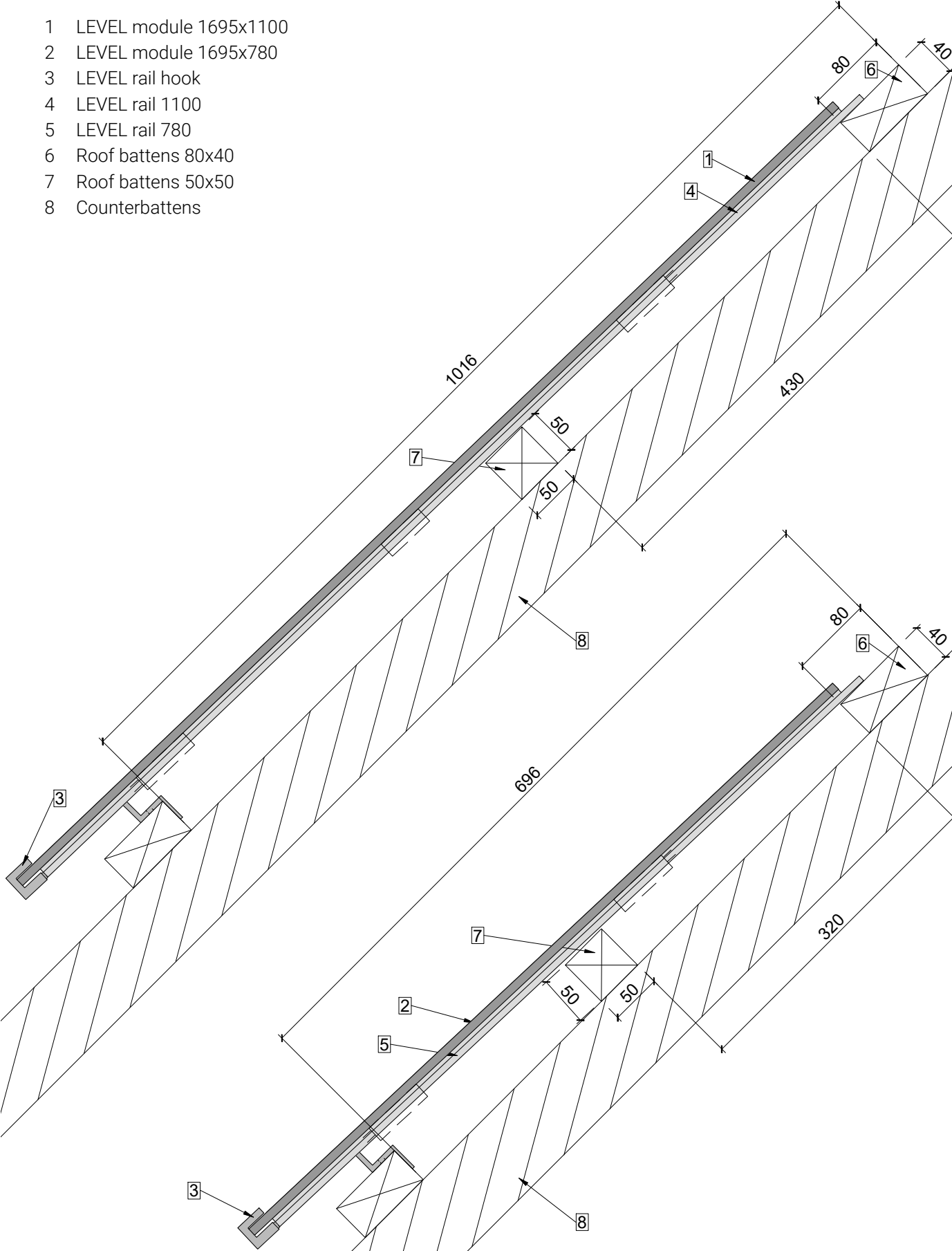

- 1 LEVEL module 1695x1100
- 2 LEVEL module 1695x780
- 3 LEVEL rail hook
- 4 LEVEL rail 1100
- 5 LEVEL rail 780
- 6 Double roof battens 50x30 (oder 24x48)
- 7 Roof battens 40x40
- 8 Counterbattens

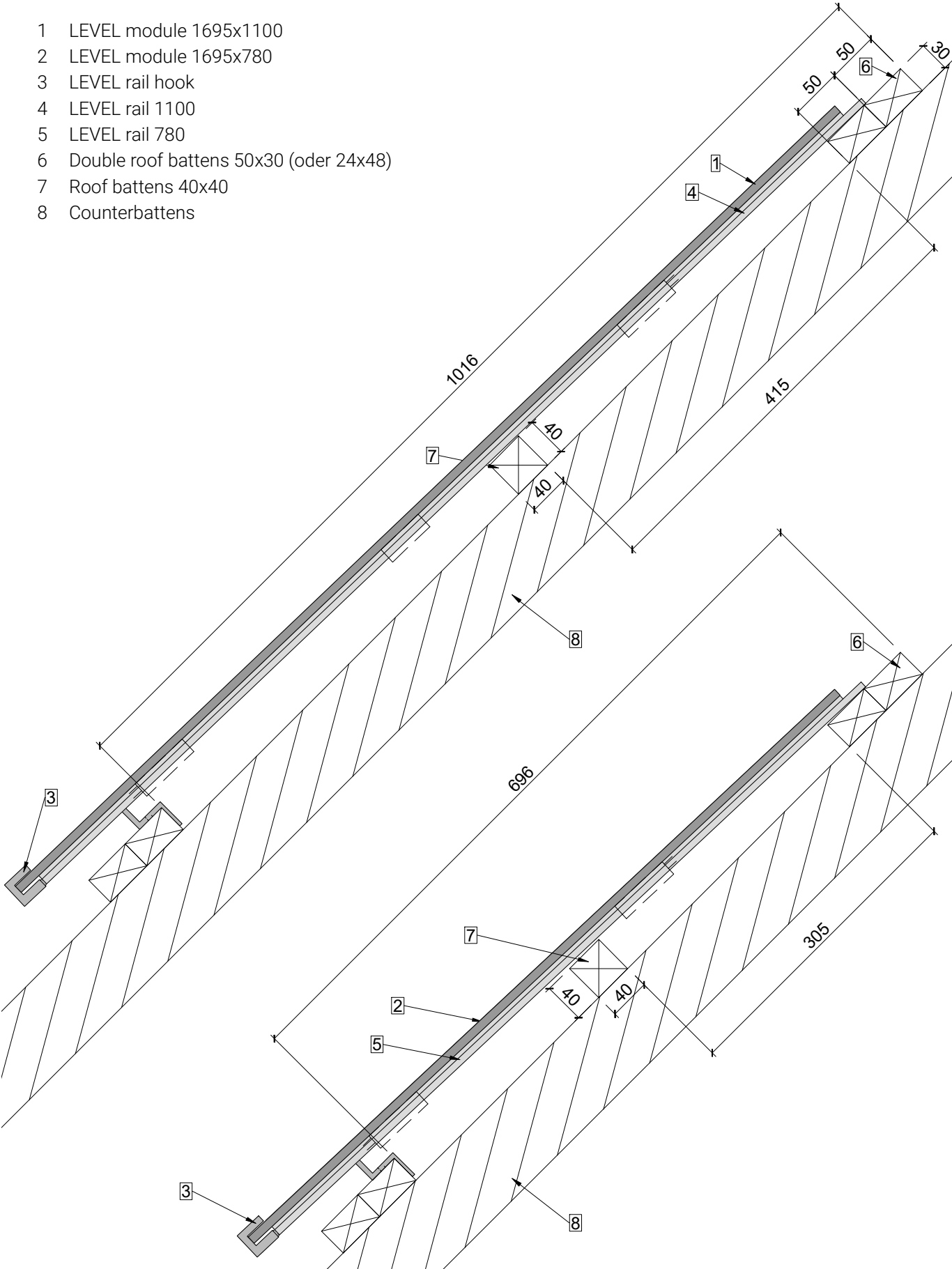

**Layout for grid dimension in height of 1016mm**

- Spans / cantilever length in millimeters
- Area load (pressure) in kN/m<sup>2</sup>, char. Value without load coefficients
- The LEVEL system must be mounted on suitable substructures that are designed for the corresponding mechanical loads of wind, snow and dead weight of the solar modules..
- System weight: approx. 22kg/m<sup>2</sup> (LEVEL standard module & mounting material)

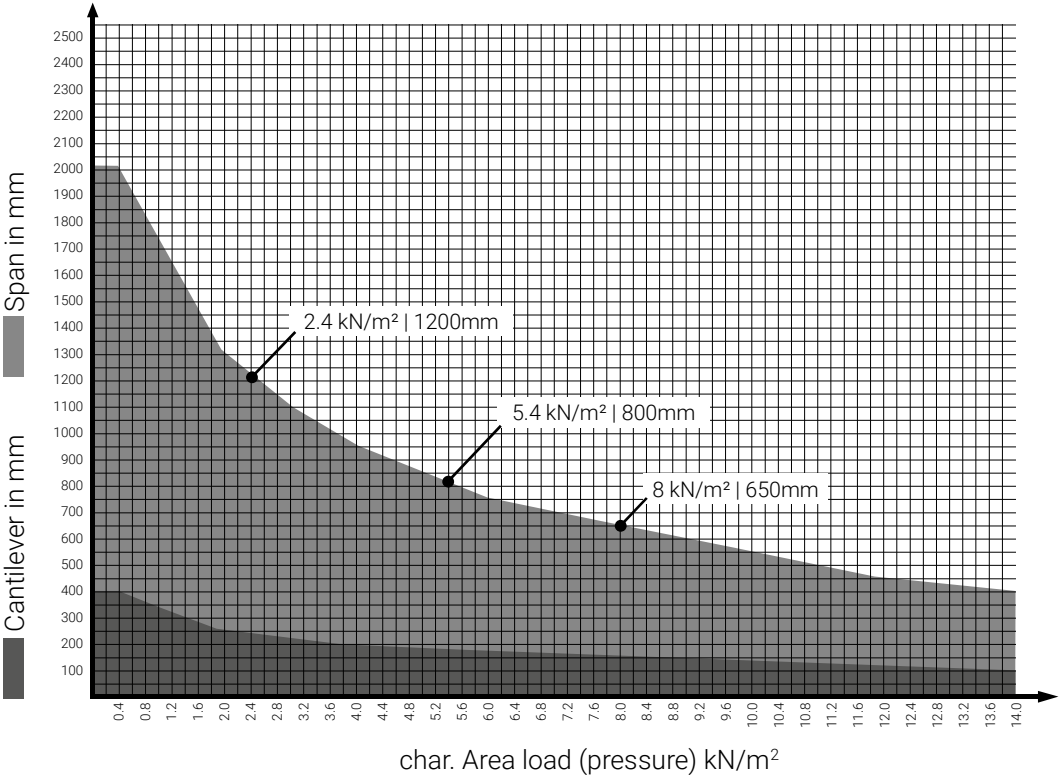

### Layout for grid dimension in height of 696mm

- Spans / cantilever length in millimeters
- Area load (pressure) in  $\text{kN/m}^2$ , char. Value without load coefficients
- The LEVEL system must be mounted on suitable substructures that are designed for the corresponding mechanical loads of wind, snow and dead weight of the solar modules.
- System weight: approx.  $22\text{kg/m}^2$  (LEVEL standard module & mounting material)

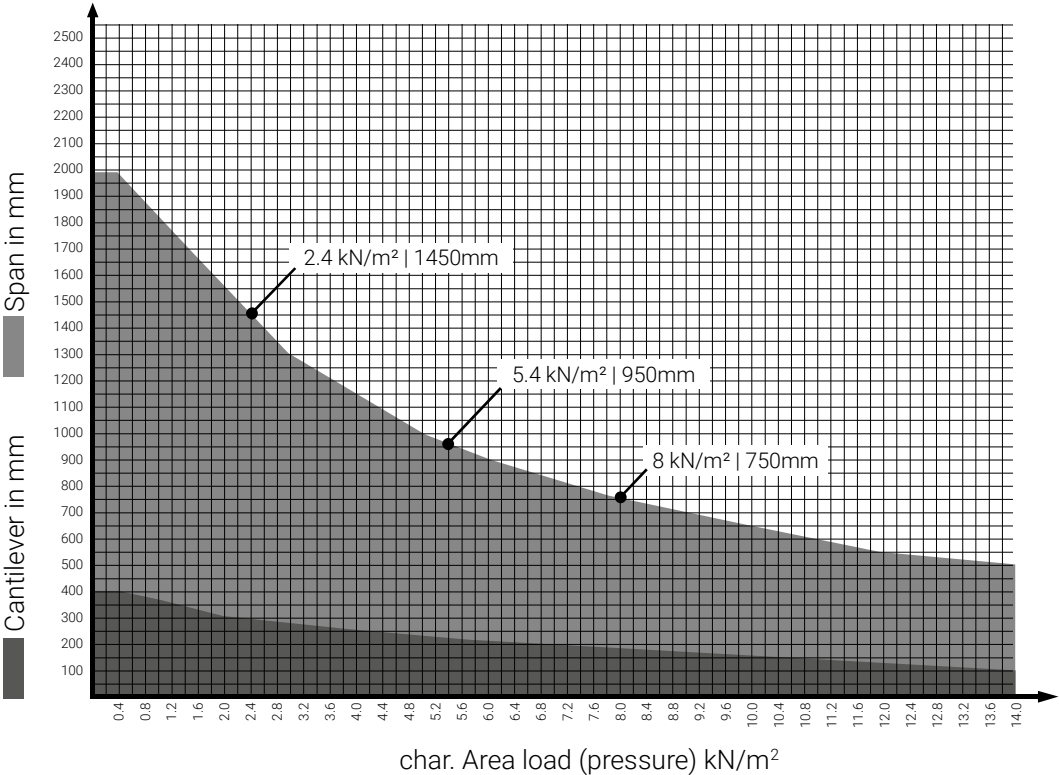



- 1 LEVEL Standard module (Grid dimension)
- 2 LEVEL Standard module half width (Grid dimension)
- 3 Roof edge

### Standard laying

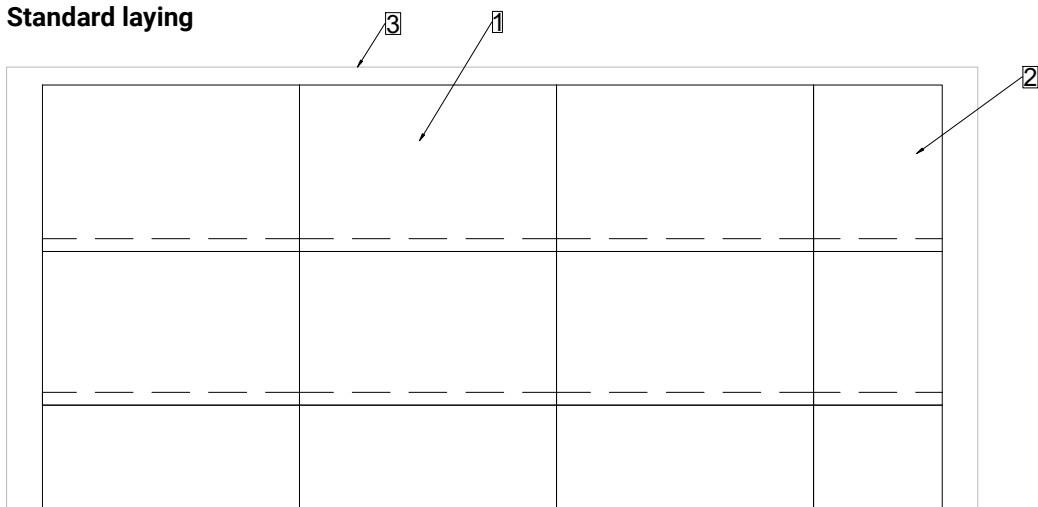

### Offset laying

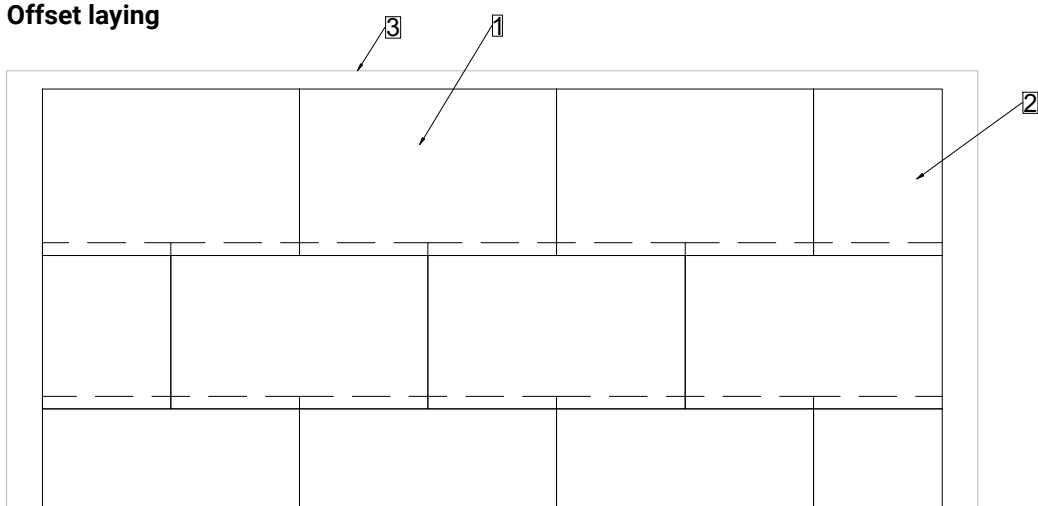

Distance to ridge, eaves and verge varies depending on the on-site finish variant.

- 1 LEVEL Standardmodule (Grid dimension)
- 2 LEVEL Customized modules (Grid dimension)
- 3 Roof edge

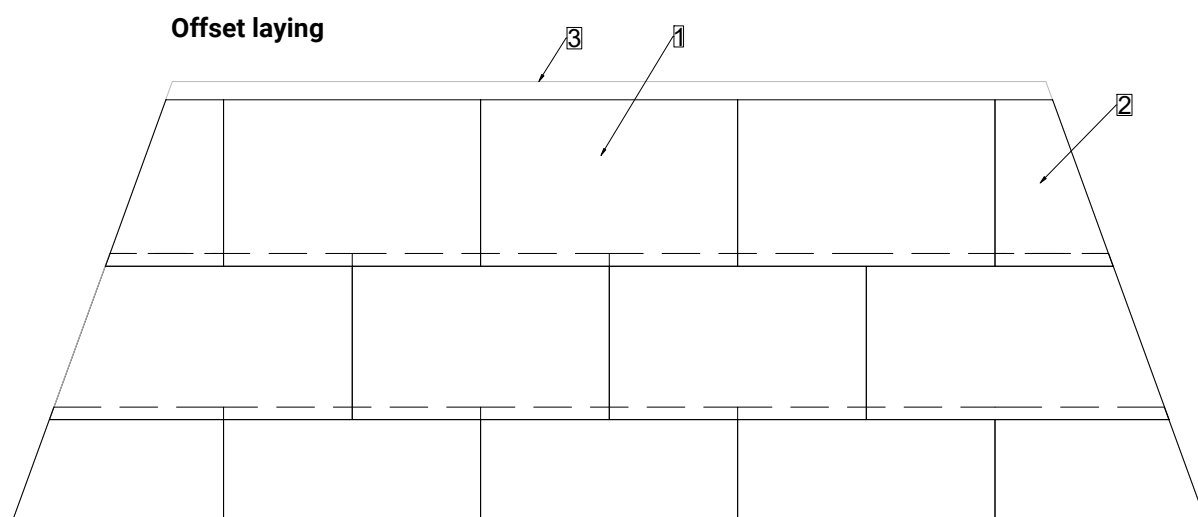
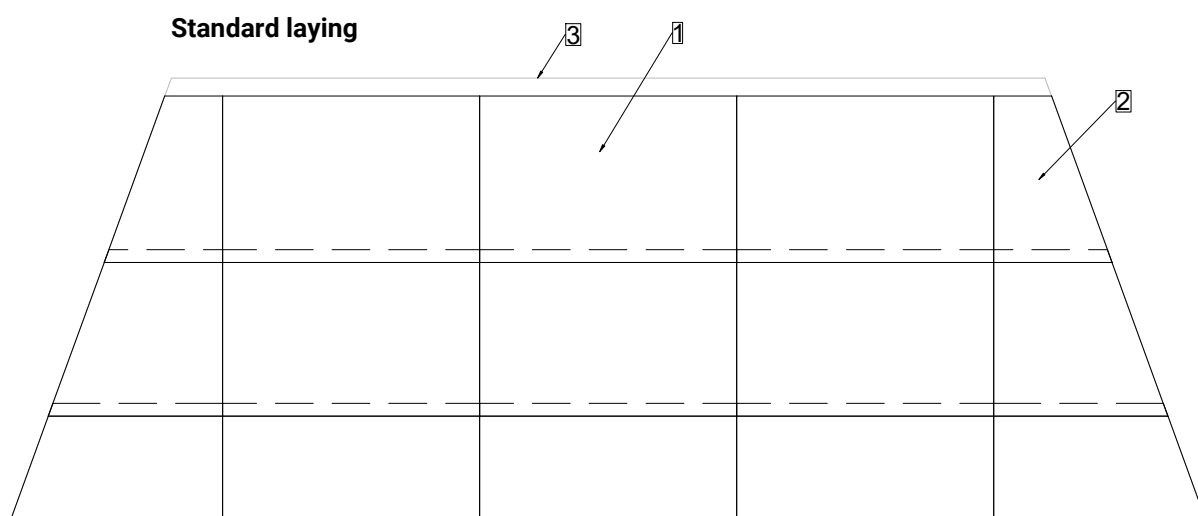

Distance to ridge, eaves and verge varies depending on the on-site finish variant.

### LEVEL Customized modules cat. 1

Module width is adjusted.

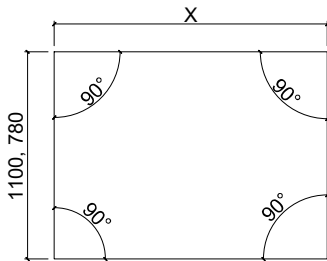

### LEVEL Customized modules cat. 2

One side skewed or Module height is adjusted.

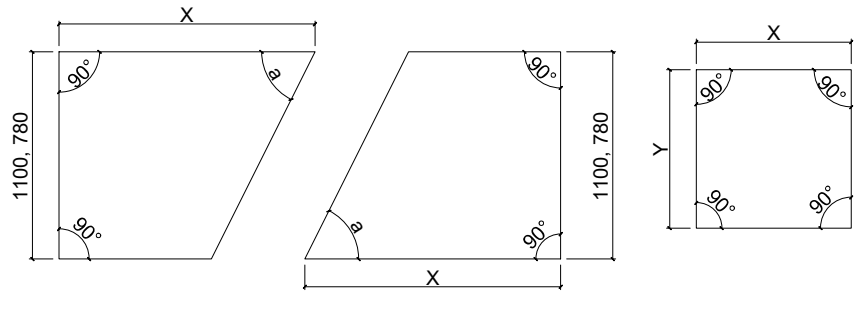

### LEVEL Customized modules cat. 3

Various changes compared to the stand modules: two sides skewed, cutouts, round shapes, holes, etc.. Depending on the shape, the realization must be checked.

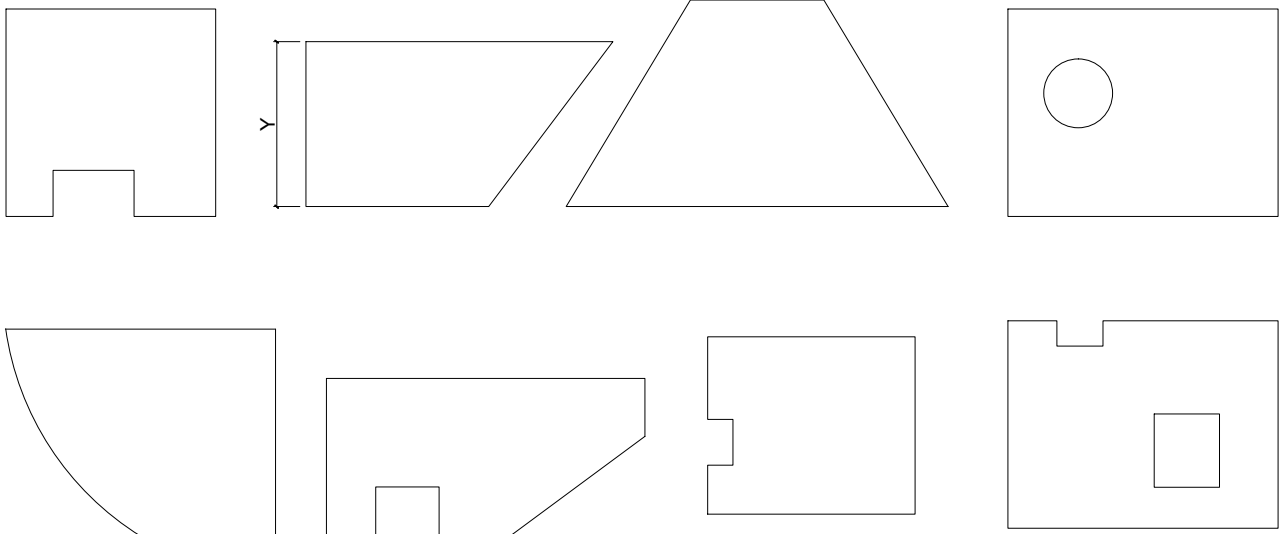

### LEVEL Customized modules cat. 4

The same modules as category 3, but without cells.

x = freely selectable dimensions from 300 mm to 3300 mm (max. cell string length: 12 cells)

y = freely selectable dimension from 460 mm to 2000 mm

(from y > 1200 the static conditions change and the layout must be checked)

Standard dimension of "LEVEL Aluminium composite module" is 1695x1100 mm.  
"LEVEL Aluminium composite module special" is cut to size.

LEVEL Aluminium composite modules can be easily reworked and therefore complicated situations (chimney, skylight, edge termination, etc.) can be solved on site with the same mounting components.

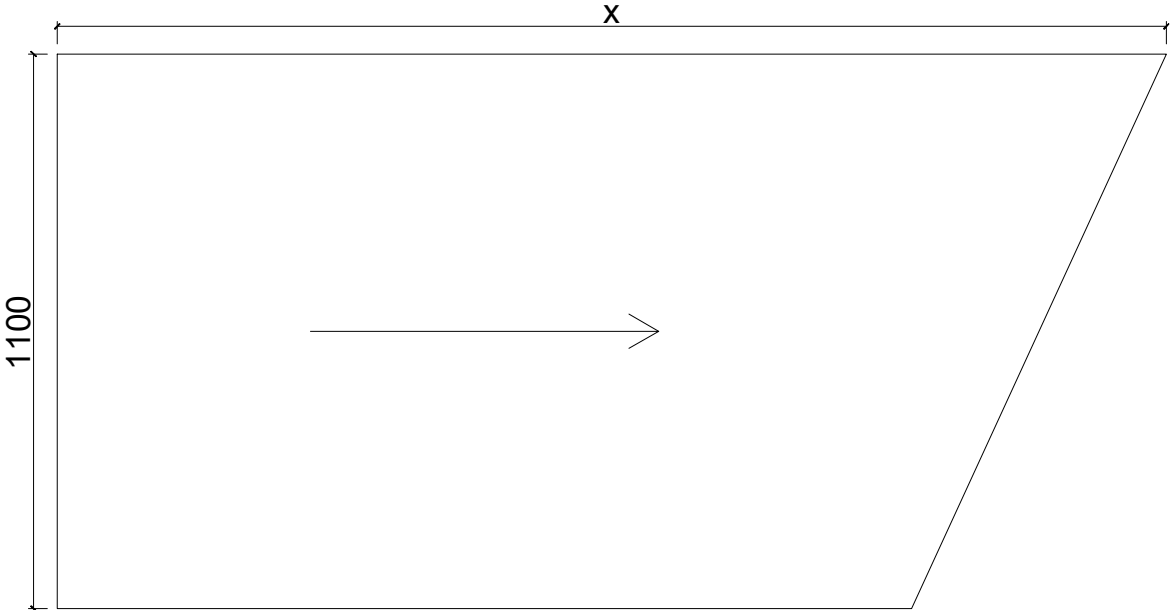
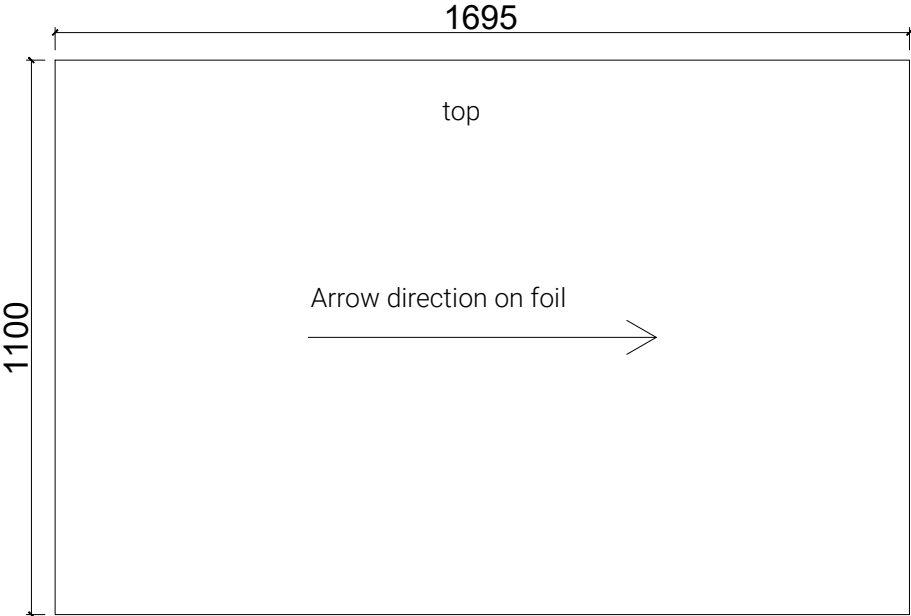

LEVEL Aluminium composite modules have a black matt coating. This coating is protected with a foil. Lay the modules so that the arrows on the foil point from left to right when looking at the roof from the front.

Module is likely to run out into the spire

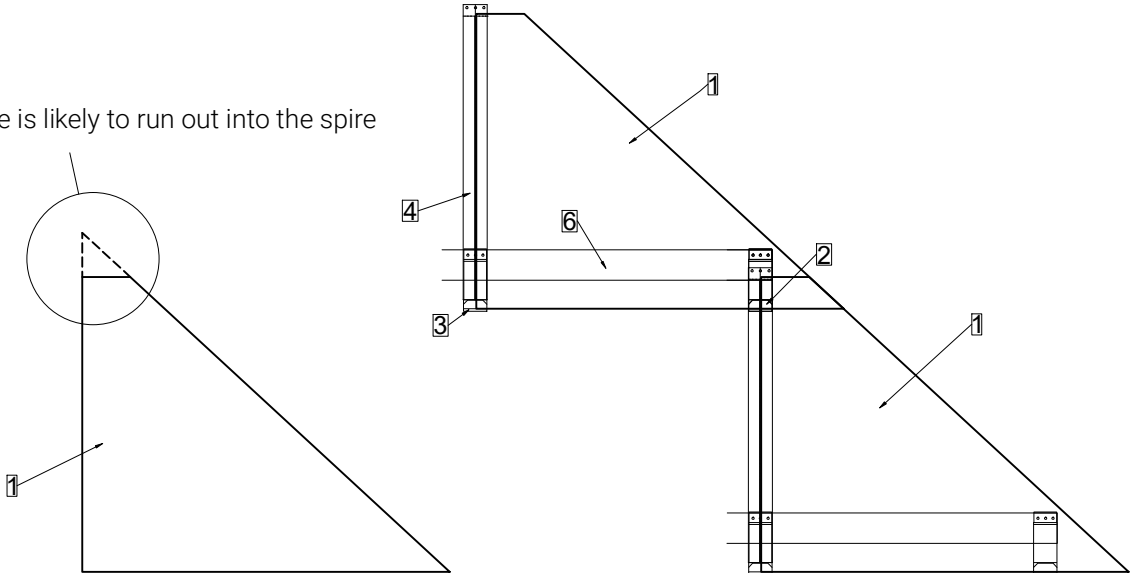

- 1 LEVEL module
- 2 LEVEL middle hooks
- 3 LEVEL rail
- 4 LEVEL side support
- 5 Roof battens 80x40

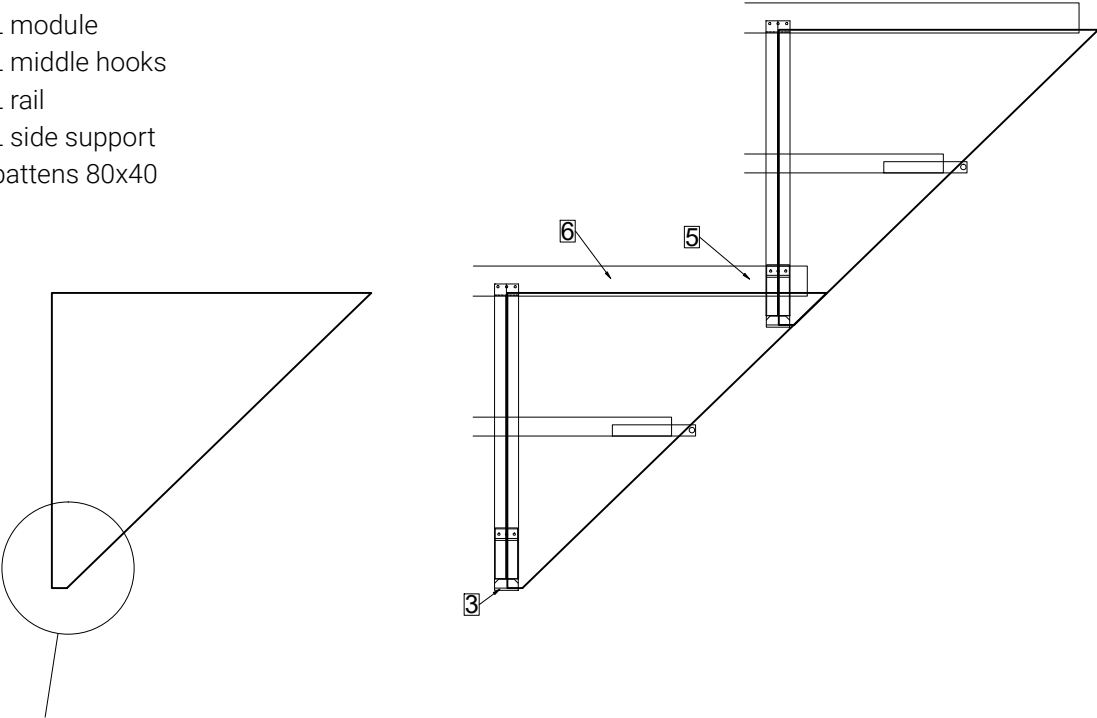

Support surface for rail hooks of at least 40 mm is necessary

For LEVEL modules to be mounted, the module must be able to rest on at least one rail hook or middle hook. The dimension of 2000x3300 mm must not be exceeded. For more complex modules, additional clarification may be necessary and when mounting customized modules, special care must be taken by the customer to ensure that the impacting forces can be withstood.

Module is allowed to run out into the peak

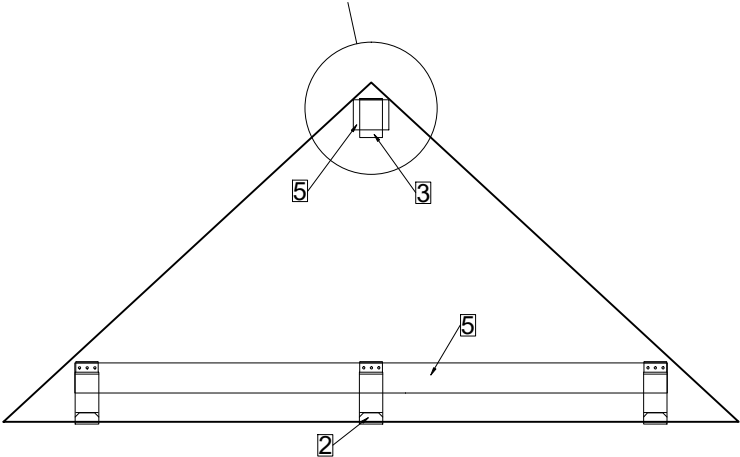

- 1 LEVEL module
- 2 LEVEL middle hooks
- 3 LEVEL support plate
- 4 LEVEL Side support
- 5 Roof battens 80x40

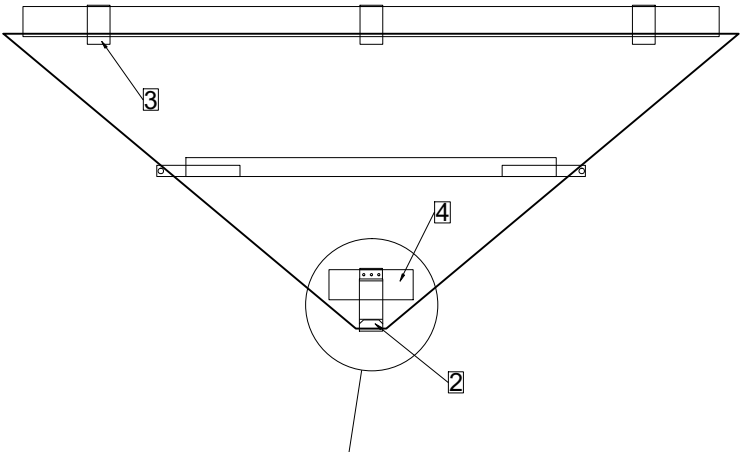

Support surface for rail hooks of at least 80 mm necessary

For LEVEL modules to be mounted, the module must be able to rest on at least one rail hook or middle hook. The dimensions of 2000x3300 mm must not be exceeded. For more complex modules, additional clarification may be necessary and when mounting customized modules, special care must be taken by the customer to ensure that the impacting forces can be withstood.

### LEVEL side support

2 pcs - d5 - 35mm thread in roof battens  
corrosion resistant

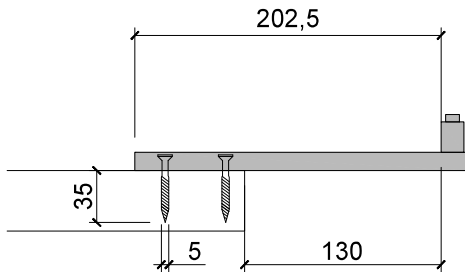

### LEVEL support plate long & short

2 resp. 1 pcs - d5 - 35mm  
countersunk head 35mm  
thread in roof battens  
corrosion resistant

### LEVEL rail

2 pcs - d5 - 35mm thread in roof  
battens corrosion resistant

### LEVEL rail hooks and middle hooks

3 pcs - d5 - 35mm thread in roof  
battens corrosion resistant

### LEVEL gancio da neve SEP

2 pcs - d8 - 80mm thread in  
counterbattens corrosion  
resistant



## Eaves finish

| A4 | 1:5 | V23.01 |

- 1 LEVEL module
- 2 LEVEL rail hooks
- 3 LEVEL rail
- 4 Roof battens 80x40
- 5 Counterbattens
- 6 Ventilation plate
- 7 Gutter
- 8 Subroof

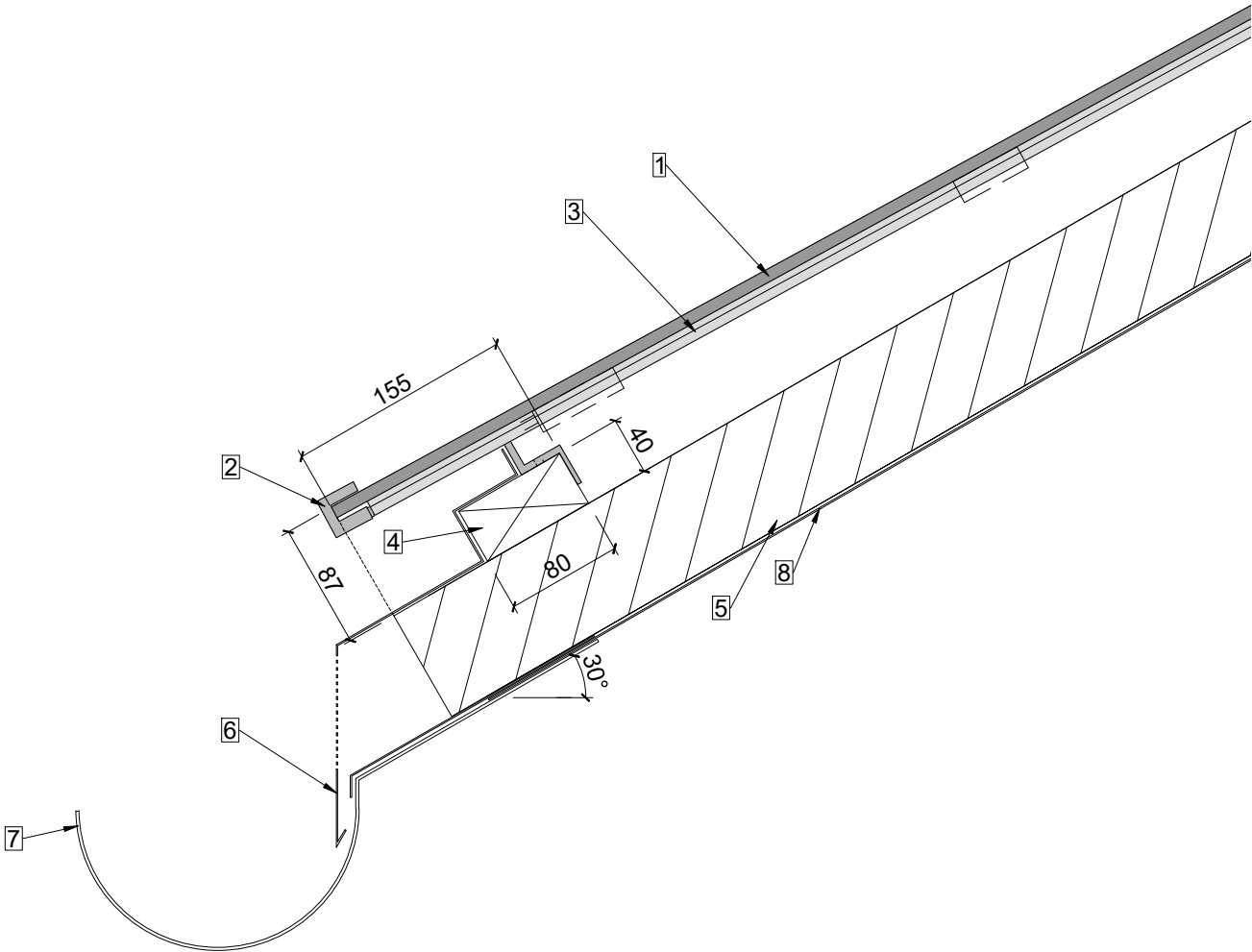

The installation situations shown serve as a suggested solution and orientation. Correct planning and execution must be adapted to local conditions and situations and is the responsibility of the contractor.



- 1 LEVEL module
- 2 LEVEL rail
- 3 aluminum composite plate
- 4 Roof battens 80x40
- 5 Horizontal battens 30x50
- 6 Counterbattens
- 7 Ventilation plate
- 8 Vertical ventilation wood 40x40
- 9 Subroof
- 10 Screw with sealing ring

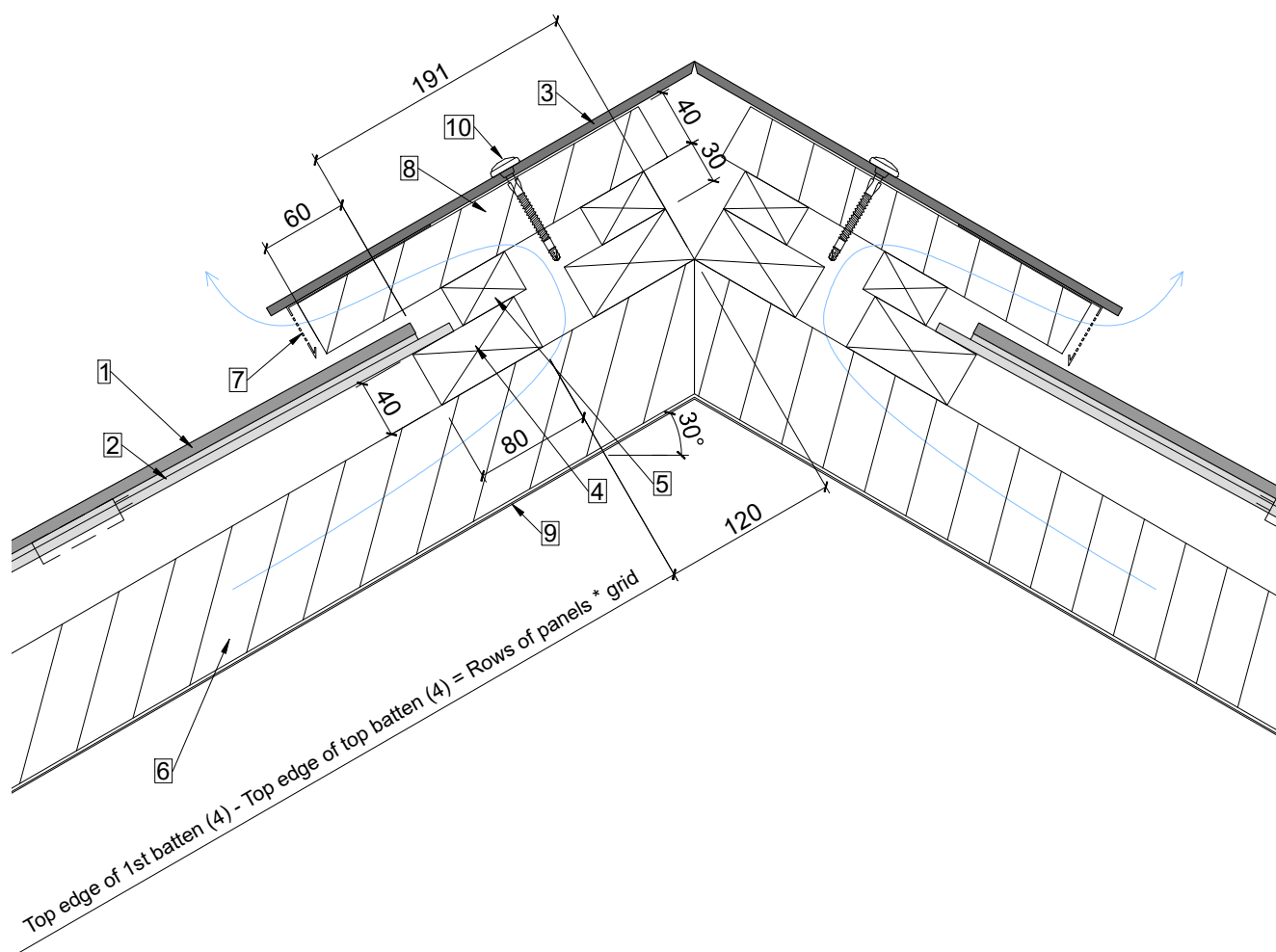

Securing the top row of modules on site.

The installation situations shown serve as a suggested solution and orientation. Correct planning and execution must be adapted to local conditions and situations and is the responsibility of the contractor.

- 1 LEVEL module
- 2 LEVEL middle hooks
- 3 LEVEL rail
- 4 aluminum composite plate
- 5 Roof battens 80x40
- 6 Vertical battens 40x38
- 7 Counterbattens
- 8 Subroof
- 9 Screw with sealing ring

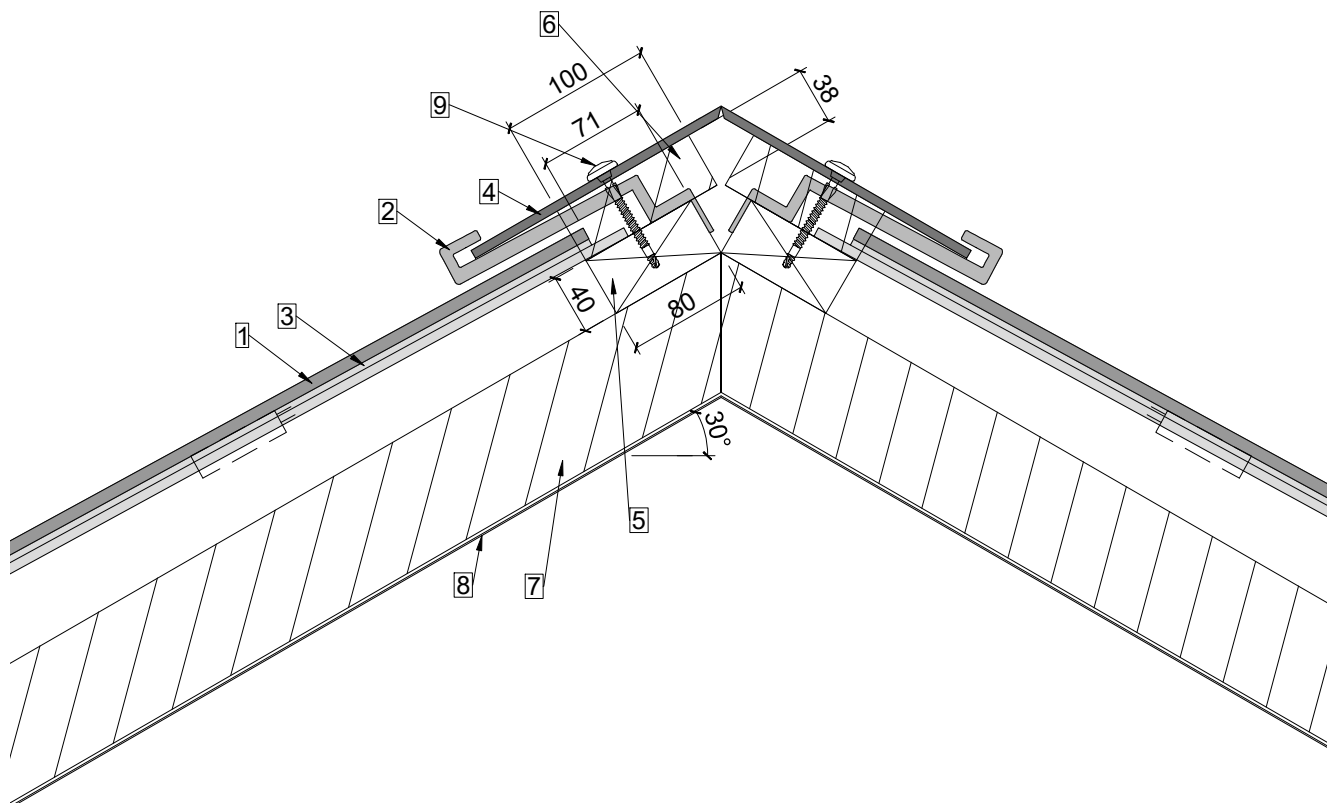

The installation situations shown serve as a suggested solution and orientation. Correct planning and execution must be adapted to local conditions and situations and is the responsibility of the contractor.

## Ridge finish with gutter

| A4 | 1:5 | V23.01 |

- 1 LEVEL module
- 2 LEVEL middle hooks
- 3 LEVEL rail
- 4 sheet metal tinsmith
- 5 Ridge gutter
- 6 Roof battens 80x40
- 7 Horizontal battens 40x40 between middle hooks
- 8 Counterbattens
- 9 Subroof
- 10 Screw with sealing ring

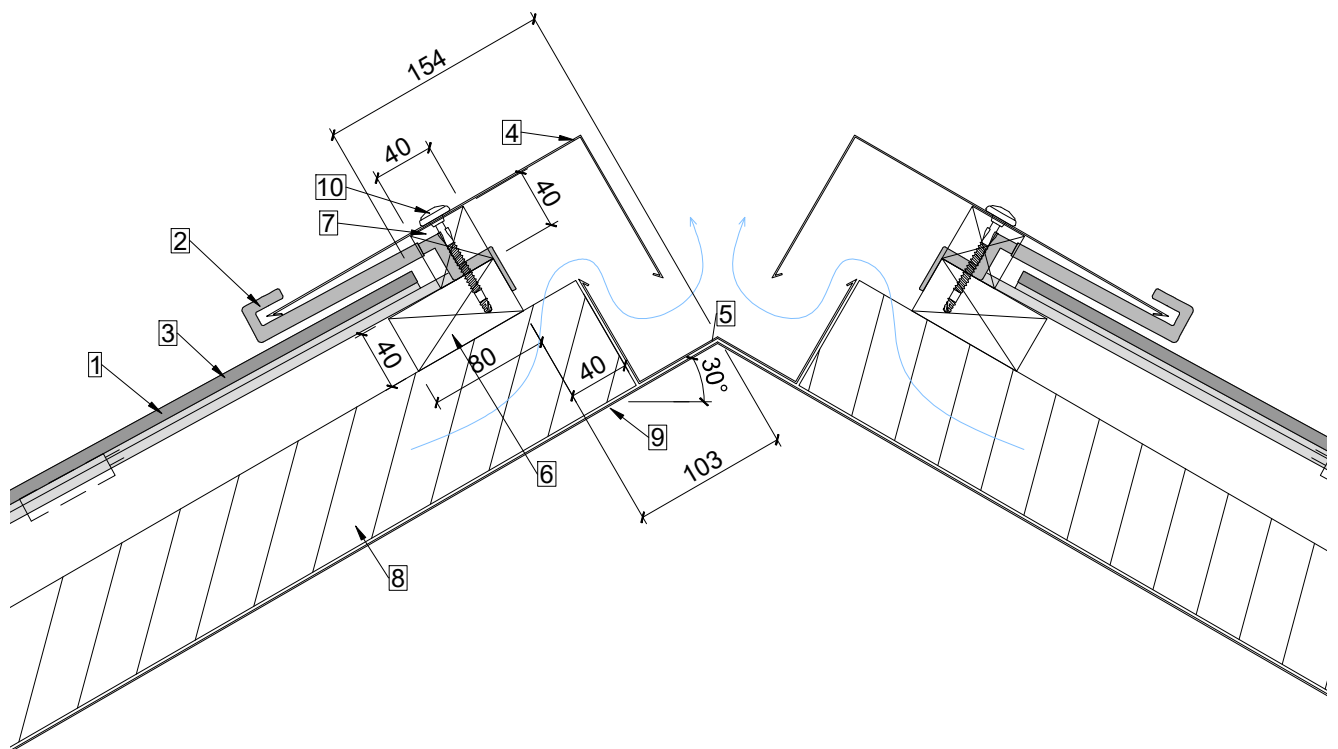

The installation situations shown serve as a suggested solution and orientation. Correct planning and execution must be adapted to local conditions and situations and is the responsibility of the contractor.

## Ridge finish with ridge tile

| A4 | 1:5 | V23.01 |

- 1 LEVEL module
- 2 LEVEL rail
- 3 Seal & Module Protection Rubber
- 4 Perforated plate
- 5 Ridge tile
- 6 Tile
- 7 Counterbattens
- 8 Roof battens 80x40
- 9 Roof battens for tiles
- 10 Subroof

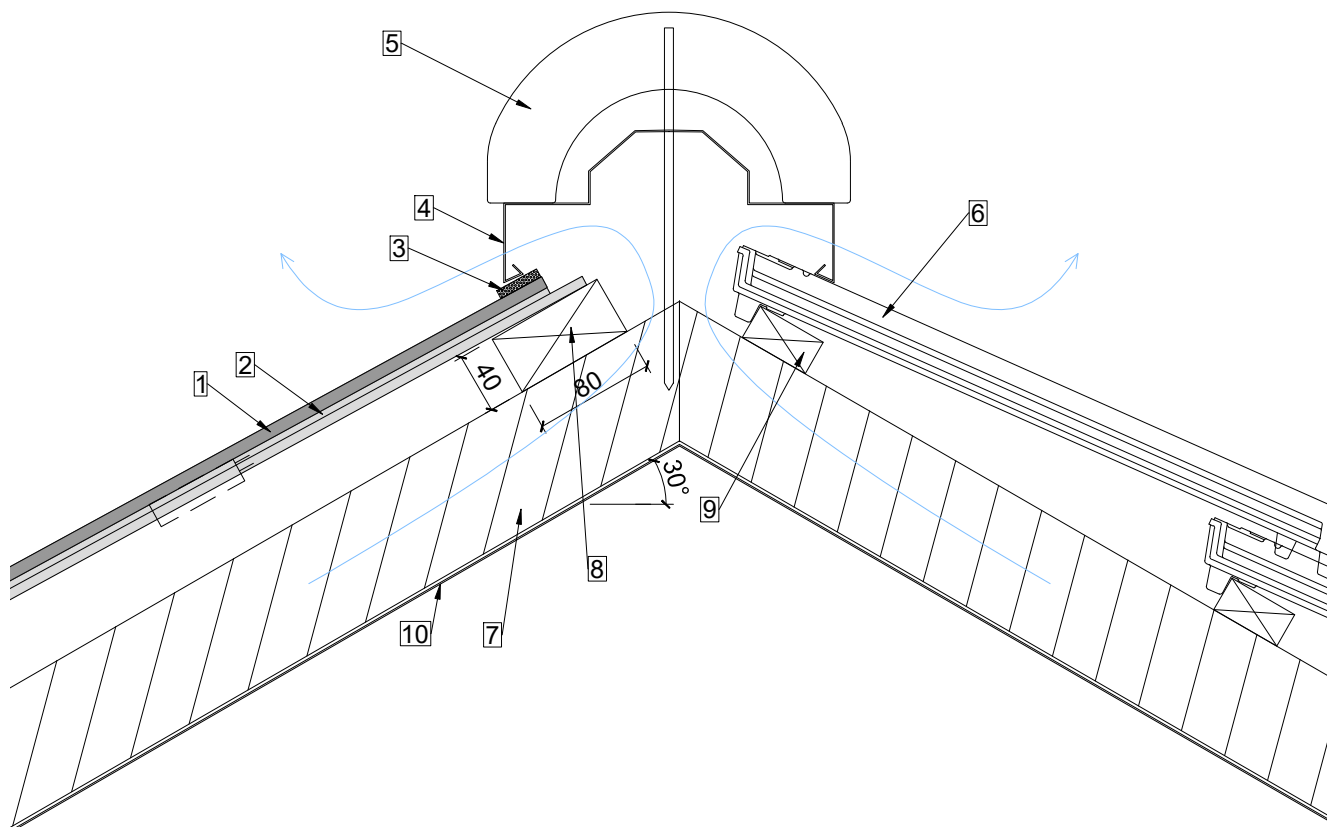

Securing the top row of modules on site.

The installation situations shown serve as a suggested solution and orientation. Correct planning and execution must be adapted to local conditions and situations and is the responsibility of the contractor.

## Ridge finish shed roof

| A4 | 1:5 | V23.01 |

- 1 LEVEL module
- 2 LEVEL middle hooks
- 3 LEVEL rail
- 4 sheet metal tinsmith
- 5 Headboard
- 6 Roof battens 80x40
- 7 Horizontal battens 40x40 between middle hooks
- 8 Counterbattens

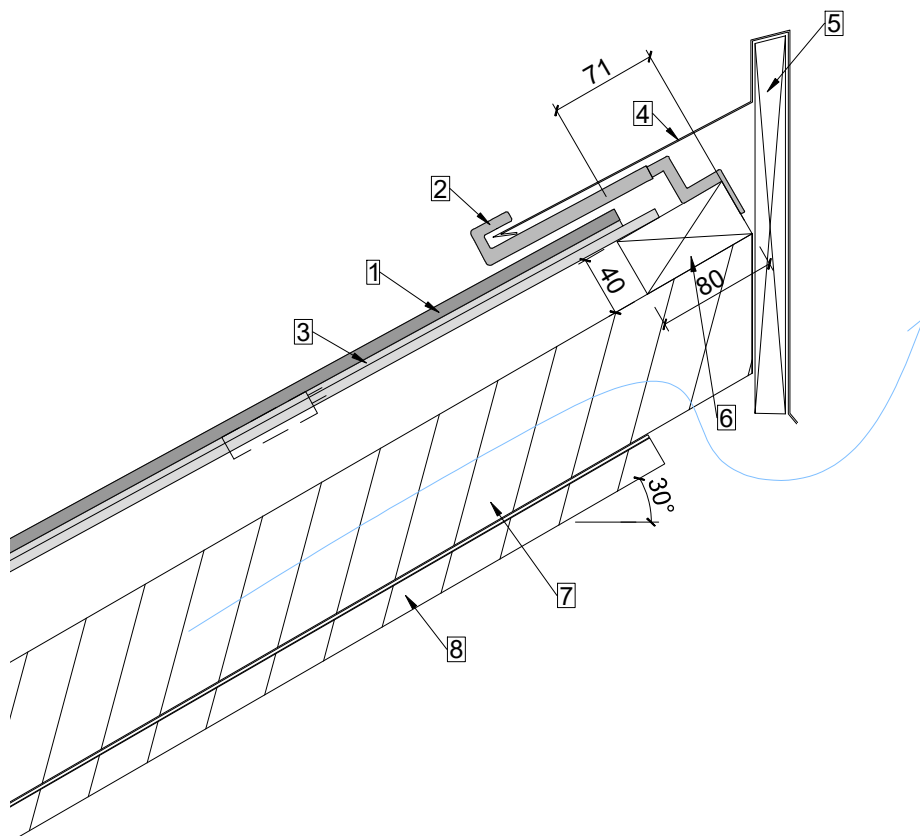

The installation situations shown serve as a suggested solution and orientation. Correct planning and execution must be adapted to local conditions and situations and is the responsibility of the contractor.

## Ridge finish shed roof with gutter

| A4 | 1:5 | V23.01 |

- 1 LEVEL module
- 2 LEVEL middle hooks
- 3 LEVEL rail
- 4 sheet metal tinsmith
- 5 Ridge gutter
- 6 Roof battens 80x40
- 7 Horizontal battens 40x40 between middle hooks
- 8 Counterbattens
- 9 Subroof
- 10 Shuttering
- 11 Rafters
- 12 Headboard
- 13 Screw with sealing ring

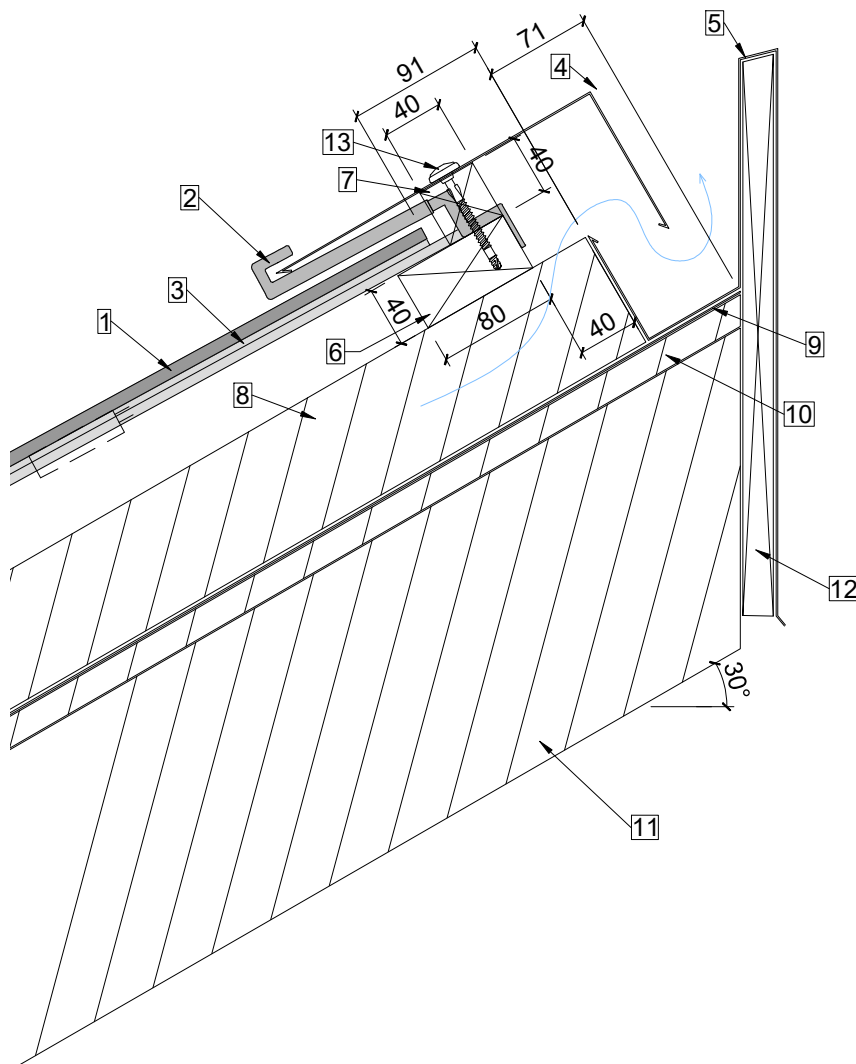

The installation situations shown serve as a suggested solution and orientation. Correct planning and execution must be adapted to local conditions and situations and is the responsibility of the contractor.

## Verge with aluminum composite plate

| A4 | 1:10 | V23.01 |

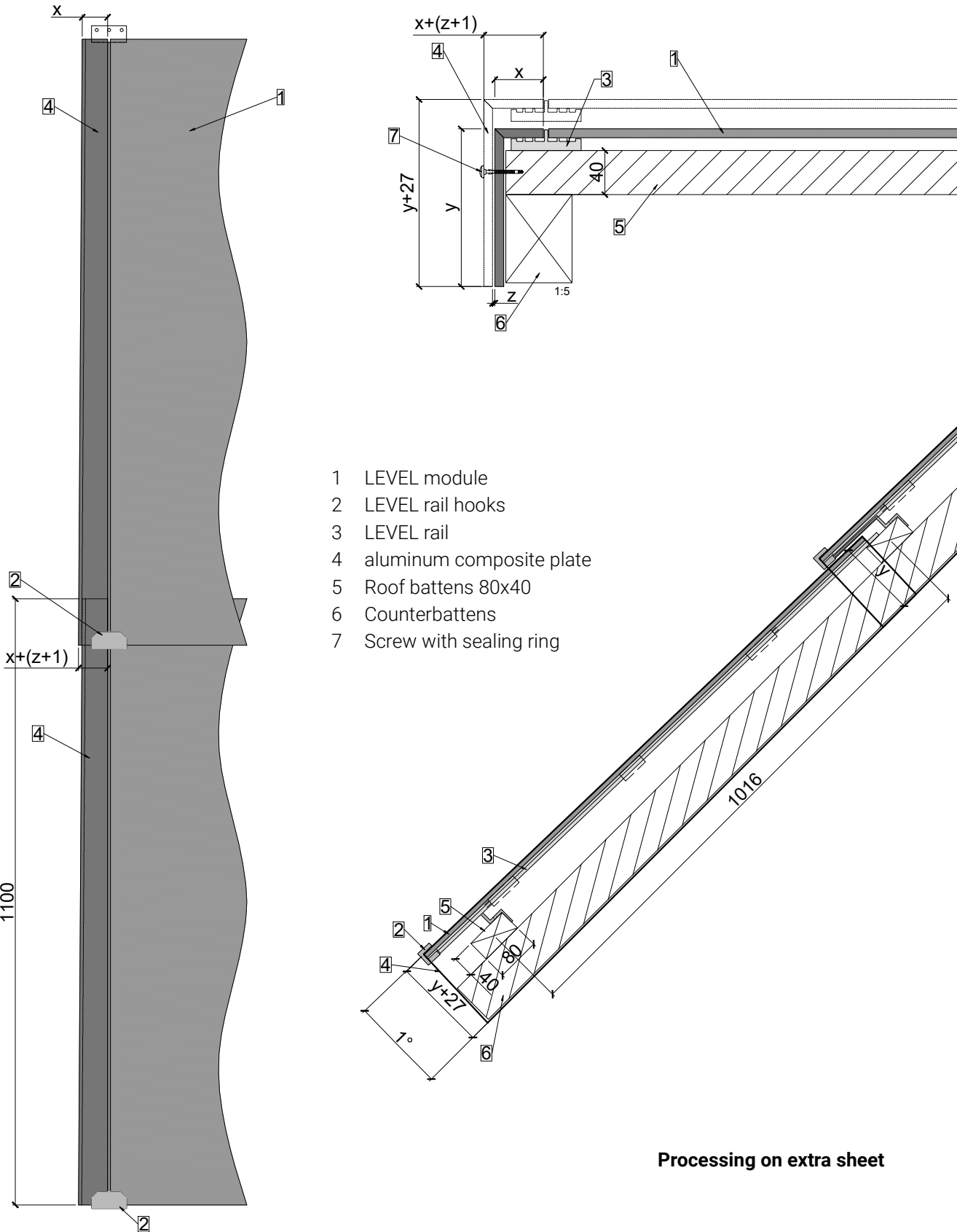

- 1 LEVEL module
- 2 LEVEL rail hooks
- 3 LEVEL rail
- 4 aluminum composite plate
- 5 Roof battens 80x40
- 6 Counterbattens
- 7 Screw with sealing ring

**Processing on extra sheet**

The installation situations shown serve as a suggested solution and orientation. Correct planning and execution must be adapted to local conditions and situations and is the responsibility of the contractor.

Processing aluminum composite plate verge left 1100 mm

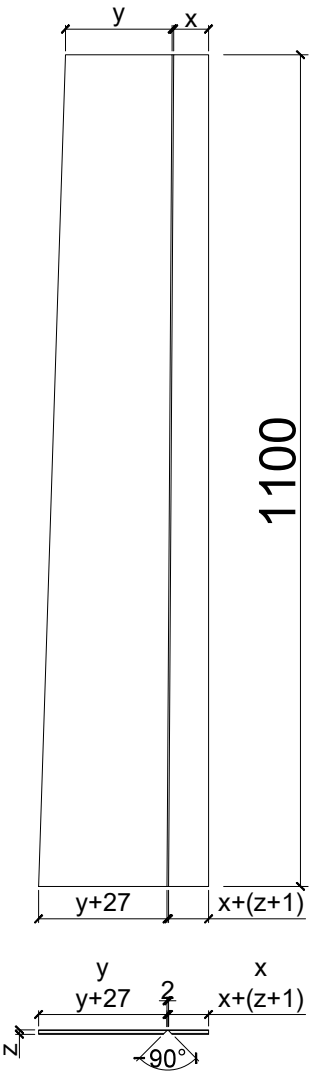

Processing aluminum composite plate verge left 780 mm

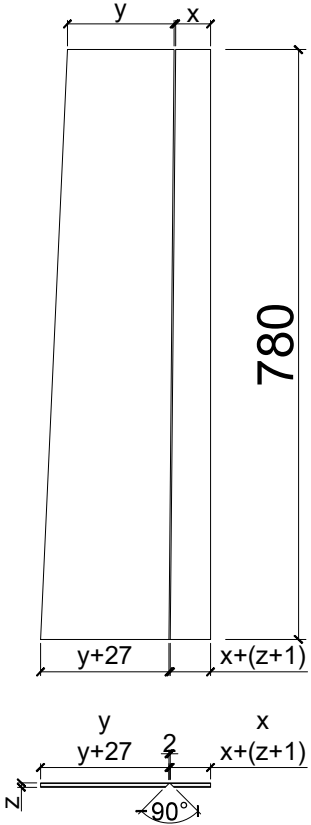



## Verge with sheet metal finish

| A4 | 1:5 | V23.01 |

- 1 LEVEL module
- 2 LEVEL rail hooks
- 3 LEVEL rail
- 4 Roof battens 80x40
- 5 Counterbattens
- 6 sheet metal tinsmith
- 7 verge plate

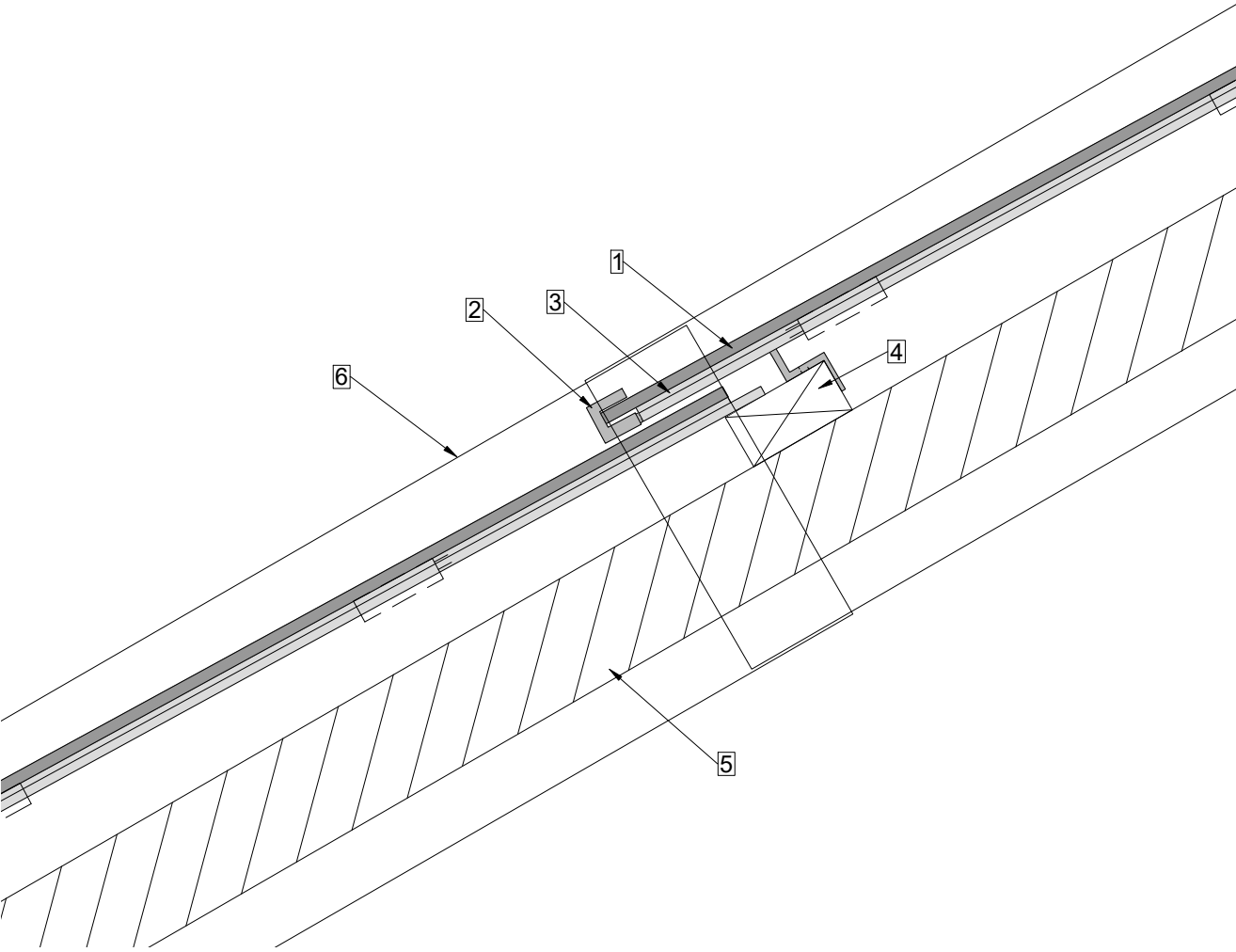
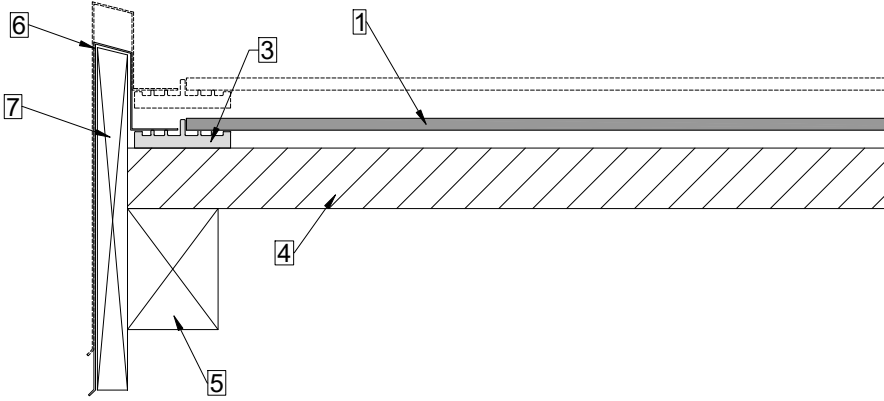

The installation situations shown serve as a suggested solution and orientation. Correct planning and execution must be adapted to local conditions and situations and is the responsibility of the contractor.

**Note the position of the junction box!**

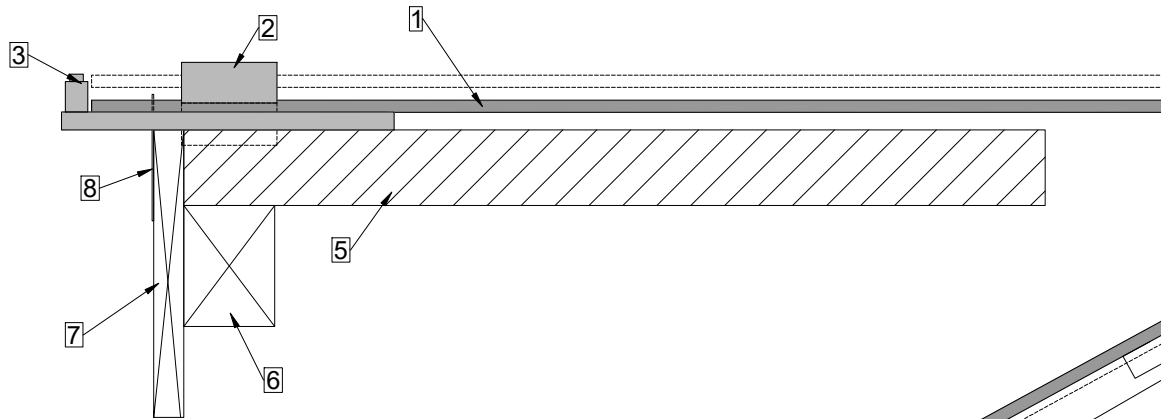

- 1 LEVEL module
- 2 LEVEL middle hooks
- 3 LEVEL Side support
- 4 LEVEL support plate
- 5 Roof battens 50x50
- 6 Counterbattens
- 7 verge plate
- 8 sheet metal tinsmith

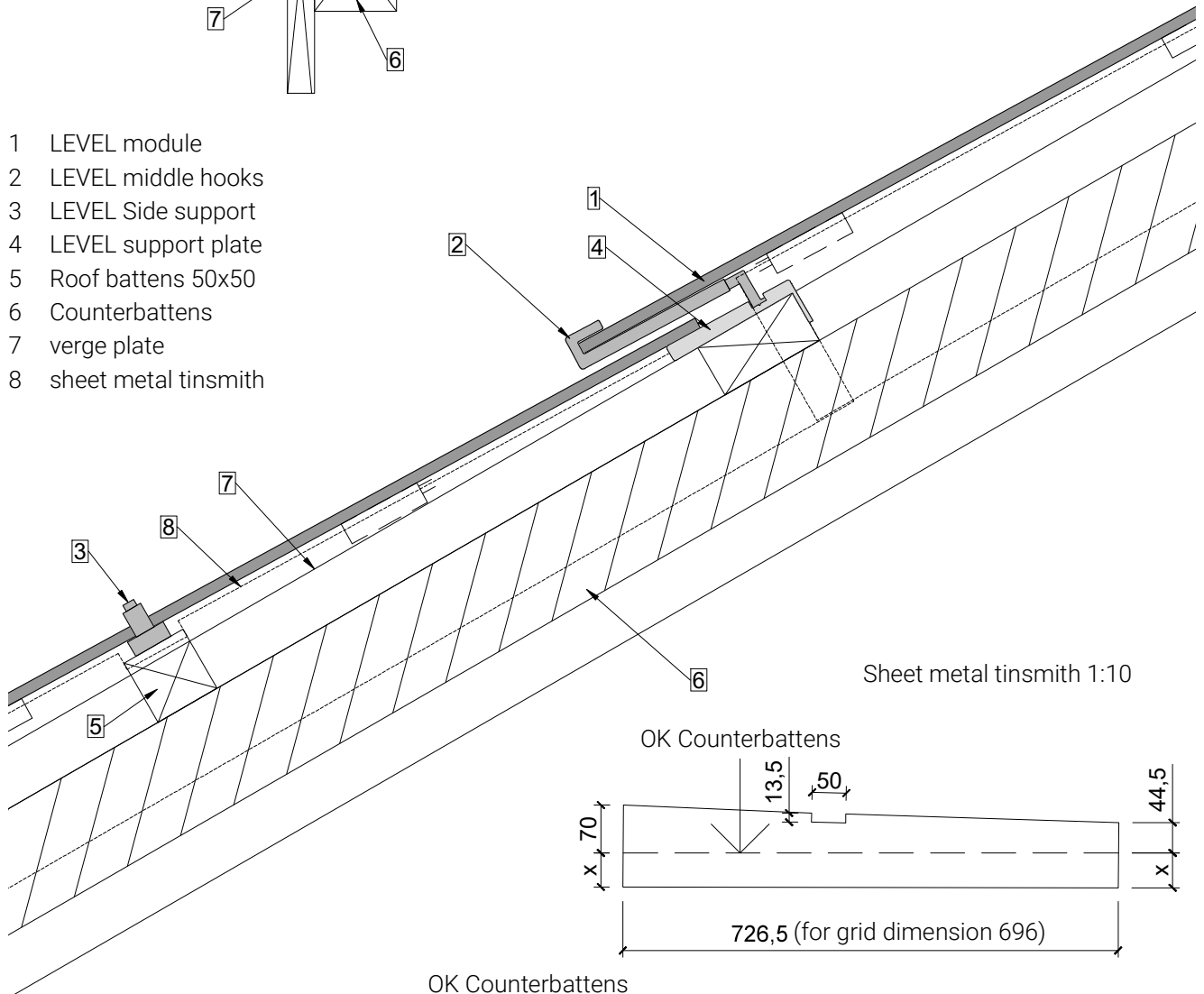

Sheet metal tinsmith 1:10

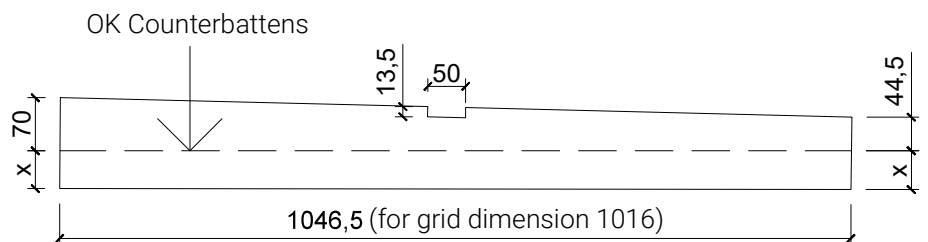
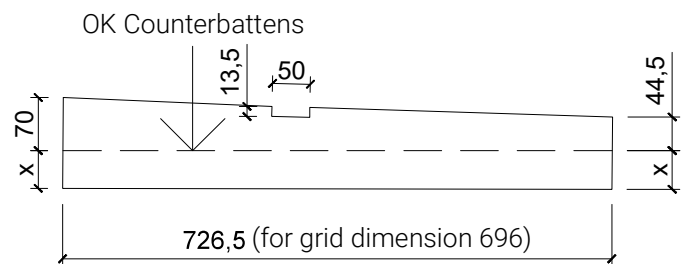

The installation situations shown serve as a suggested solution and orientation. Correct planning and execution must be adapted to local conditions and situations and is the responsibility of the contractor.

- 1 LEVEL module
- 2 LEVEL middle hooks / rail hooks
- 3 Wooden board
- 4 Counterbattens
- 5 LEVEL snow guard SEP (snow hook SEP with snow guard plate SEP)
- 6 LEVEL snow guard pipe
- 7 Screws in counterbattens

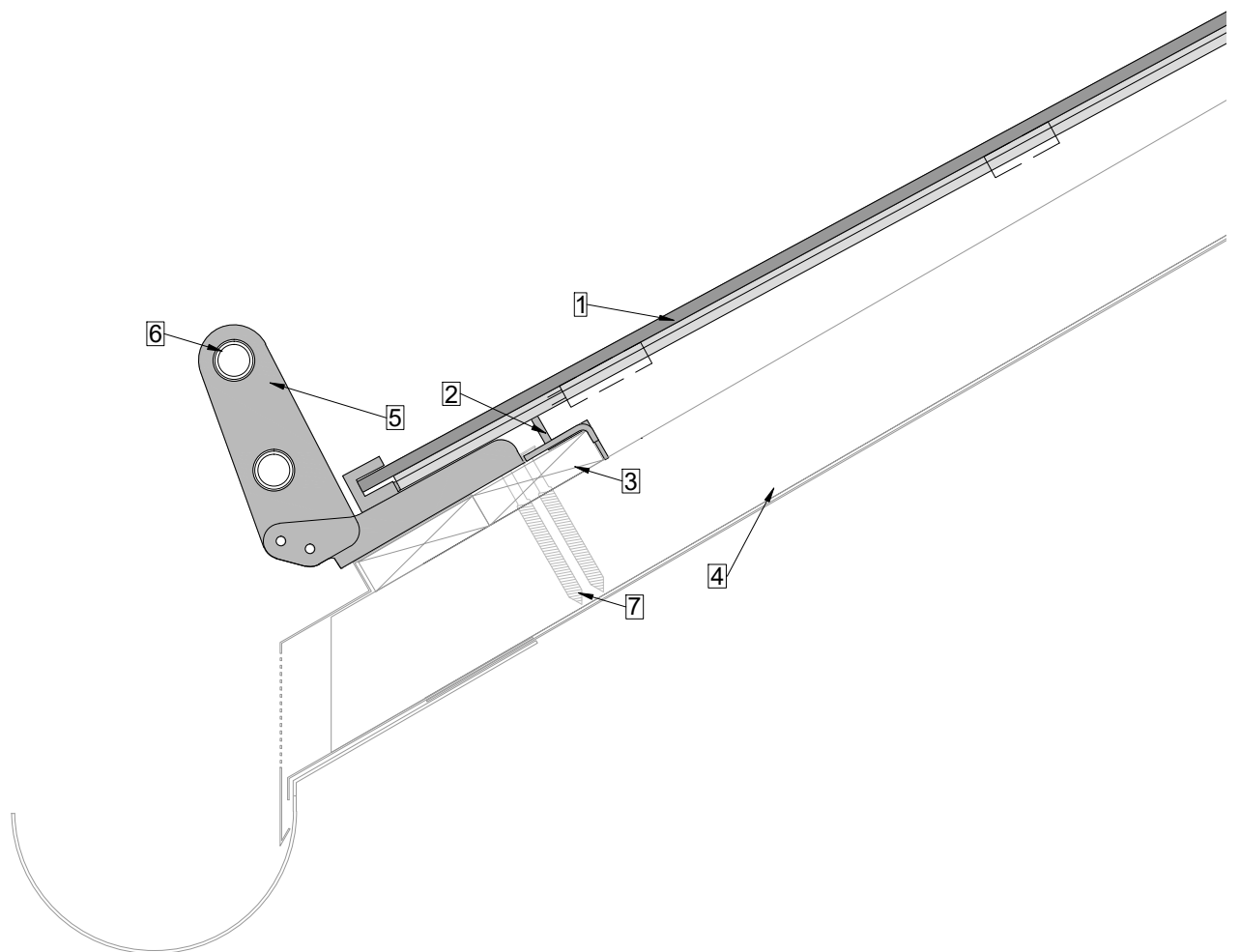

Snow hook SEP is placed under each hook and screwed into the counterbattens.

"Snow guard plate" to be fixed with M6 screws after inserting the modules.

For increased demands Megasol recommends to use the SEP Max

## For increased demands

- 1 LEVEL Aluminium composite module
- 2 LEVEL Snow guard over aluminum composite
- 3 Hanger bolt 400 mm with sealing function (100 mm in rafters)
- 4 LEVEL Middle hook under snow guard
- 5 Roof battens 80x40
- 6 Counterbattens
- 7 Rafters
- 8 LEVEL snow guard pipe

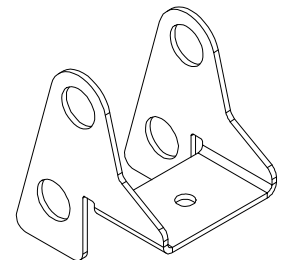

LEVEL snow guard over aluminum composite

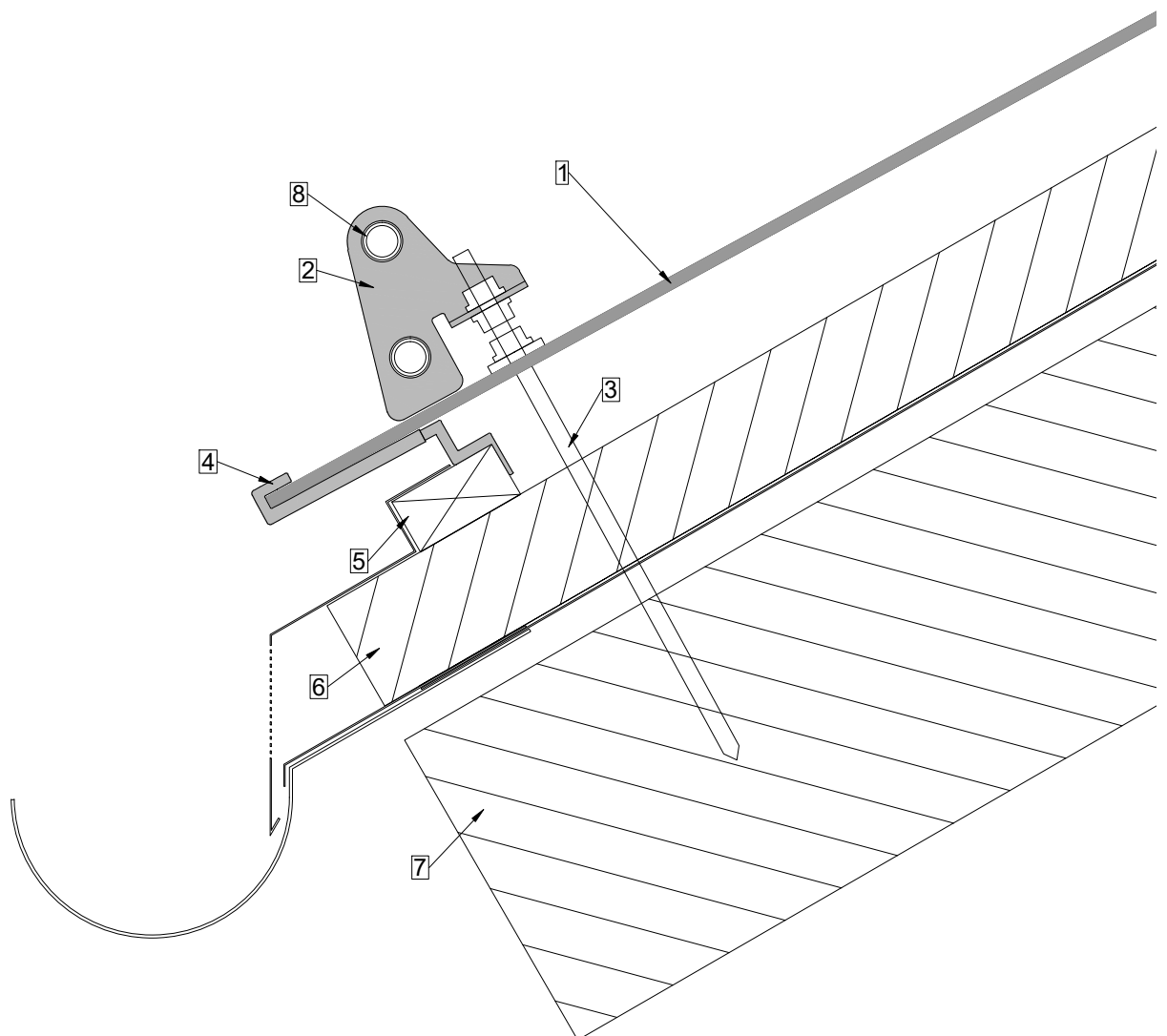

The "LEVEL snow guard over aluminum composite" is installed over each rafter, or at least 3 per module.  
The "LEVEL snow guard over aluminum composite" is recommended from an altitude of 800 m above sea level.

## Roof break with LEVEL module

| A4 | 1:20 | V23.01 |

- 1 LEVEL module
- 2 LEVEL rail
- 3 LEVEL rail hooks
- 4 Roof battens 80x40
- 5 Roof battens 50x50
- 6 Roof battens 40x40
- 7 Counterbattens
- 8 Perforated plate (e.g. 200x60x2)
- 9 Screw connection rail / perforated plate

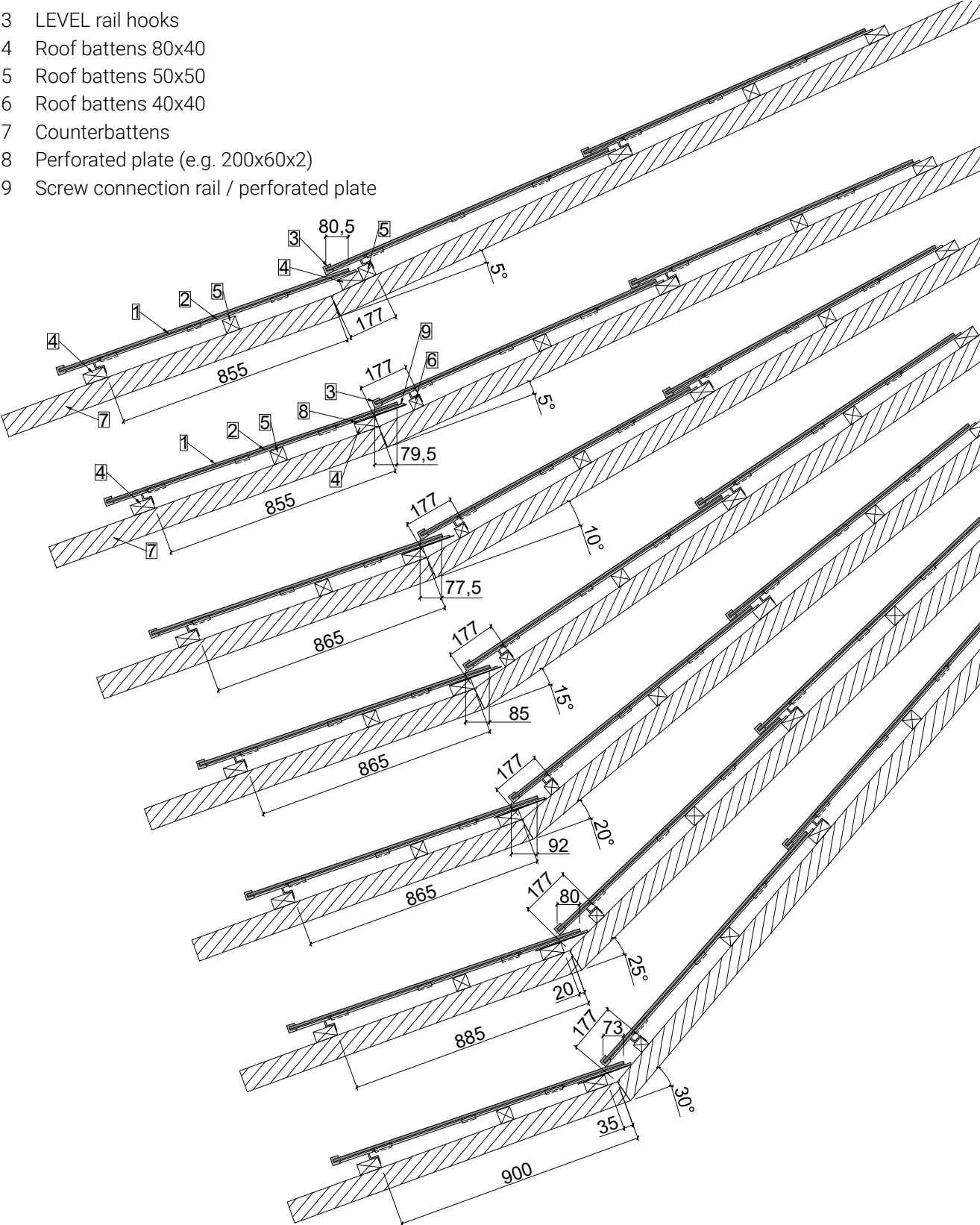

Roof breaks above 30° also possible.

- 1 LEVEL module
- 2 LEVEL rail
- 3 LEVEL rail hooks
- 4 LEVEL middle hooks
- 5 Roof battens 80x40
- 6 Roof battens 50x50
- 7 Sheet metal tinsmith
- 8 aluminum composite plate
- 9 Perforated plate (e.g. 200x60x2)
- 10 Screw connection rail / perforated plate

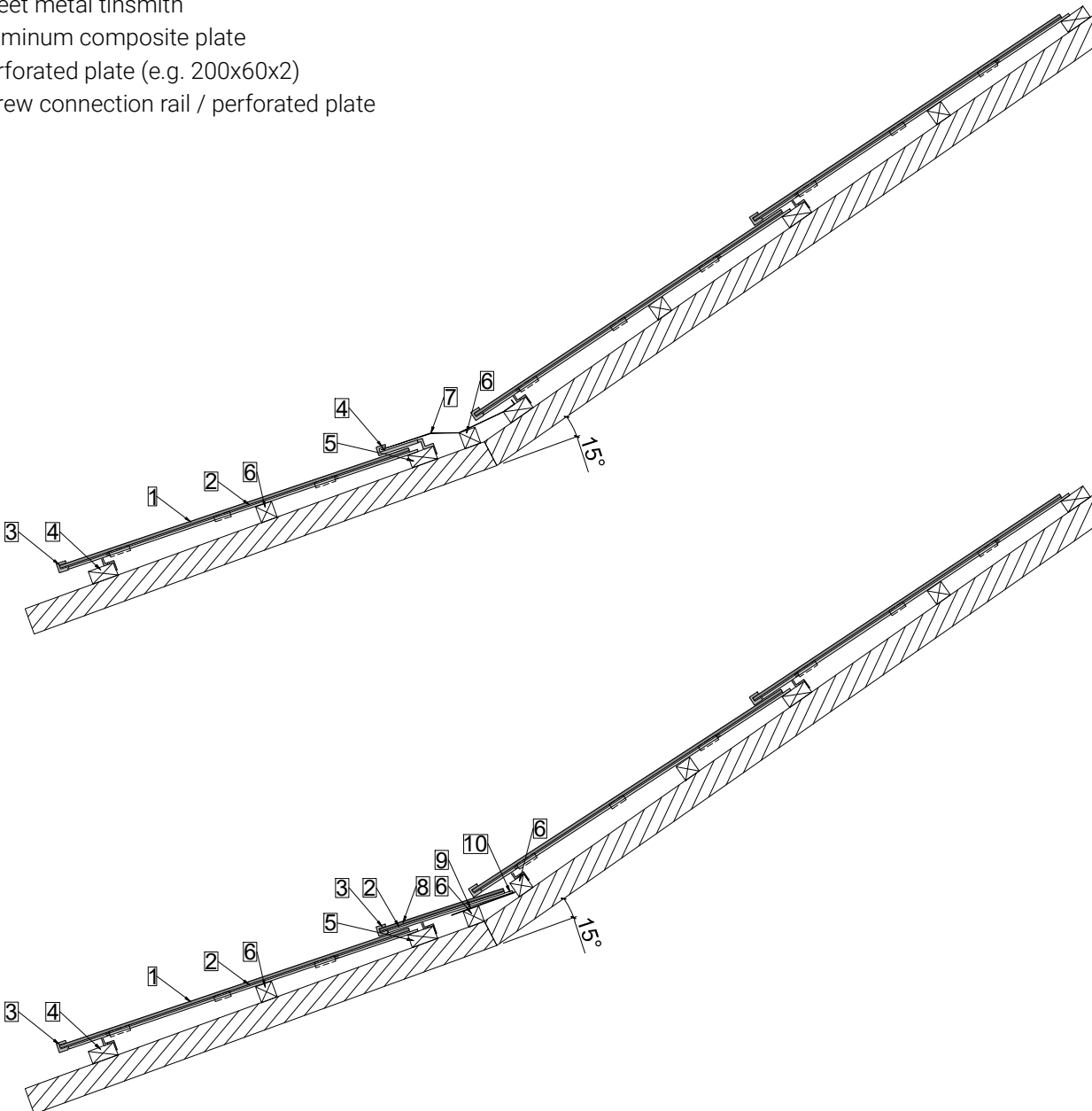

Roof breaks 1° - 90° possible.

## Support plate

| A4 | 1:5 | V23.01 |

- 1 LEVEL module 1695x1100
- 2 LEVEL module 1695x780
- 3 LEVEL middle hooks
- 4 LEVEL support plate long
- 5 LEVEL support plate short
- 6 Roof battens 80x40
- 7 Roof battens 50x50
- 8 Counterbattens

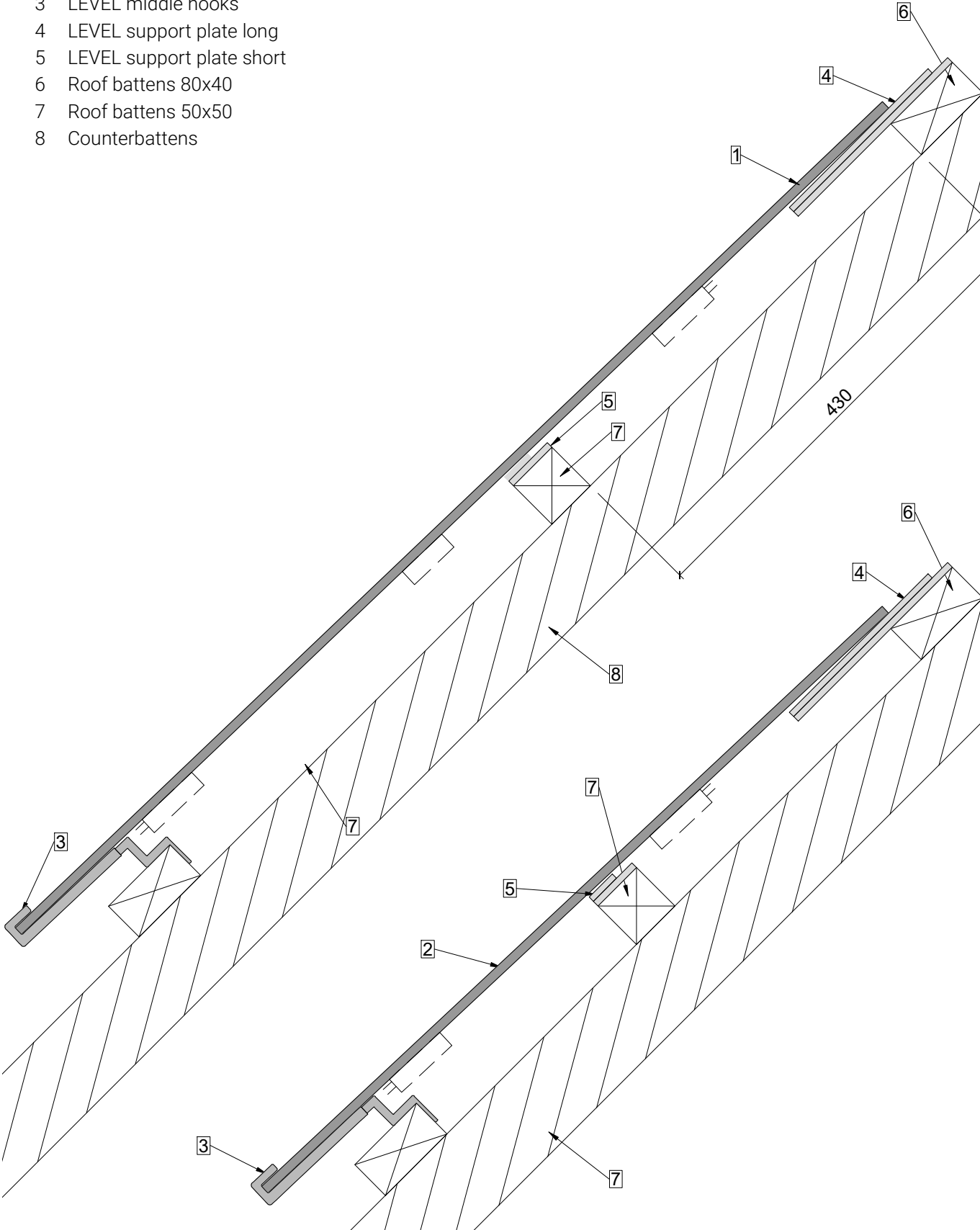

- 1 LEVEL module
- 2 LEVEL Rail hook BliSchu (on demand)
- 3 LEVEL rail

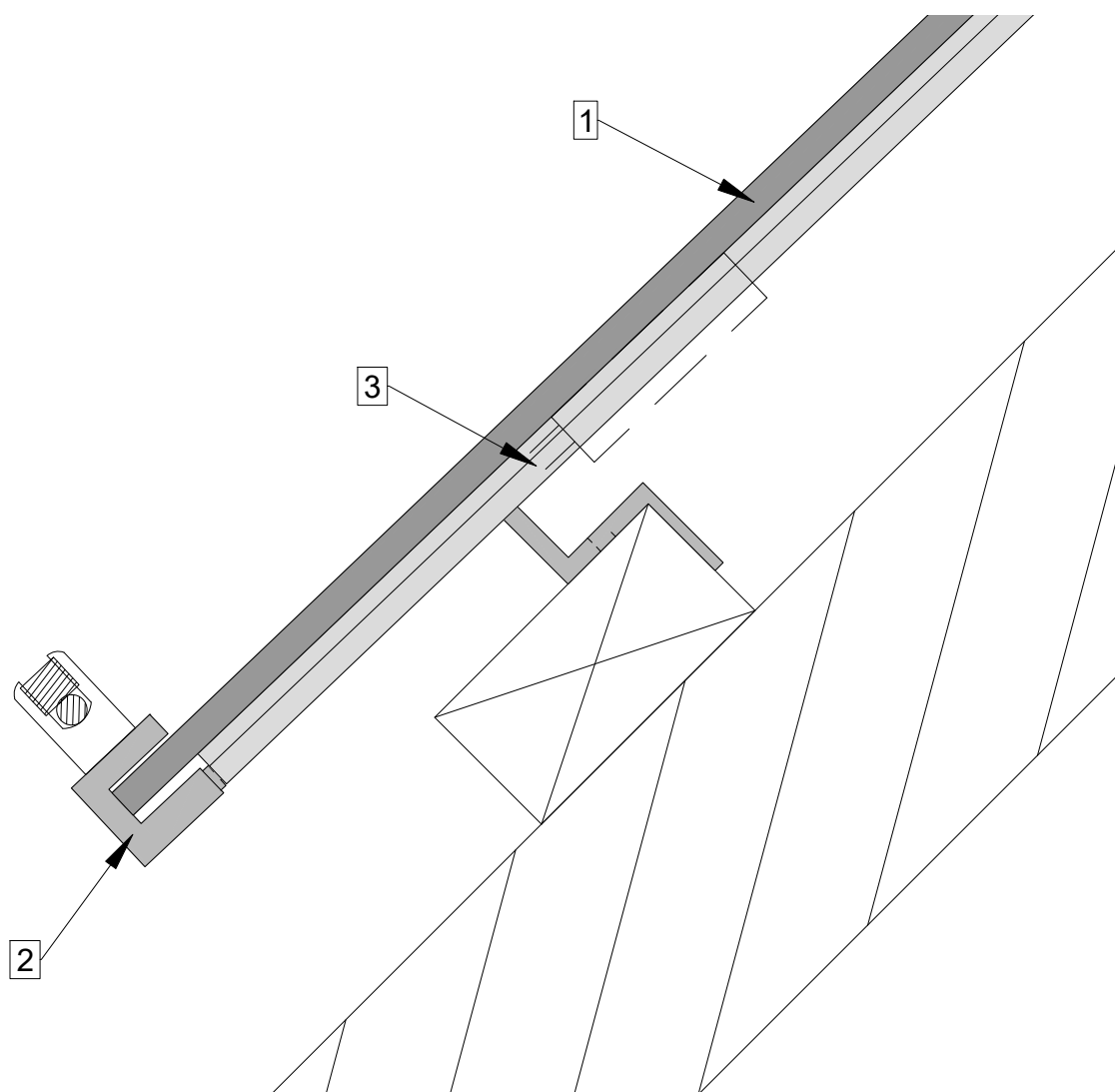

Note: Even with careful planning and execution of the lightning protection system, very high voltages can be induced in the PV module in the event of a lightning strike, which can lead to damage to the PV module. The LEVEL rail hook BliSchu is a fastening option for the lightning protection wire, which is designed to protect the building when professionally laid out. The lightning protection must be designed by specialists.

### General information about LEVEL and lightning protection:

According to the common opinion of leading lightning protection manufacturers, it is not necessary to integrate the LEVEL rails and hooks into the lightning protection system because the PV modules do not have a metal frame and are made of insulating material (glass). Other metal parts such as end plates, snow guards, etc. must be integrated. However, we would like to point out that the interpretation authority lies with the cantonal building insurance.



Certified according to EN 795A:2012 type A and CEN/TS 16415:2013 for max. 2 persons.

- 1 LEVEL module
- 2 LEVEL & MATCH Slate safety hooks
- 3 Wooden board for support
- 4 Screw according to assembly instruction
- 5 Roof battens 80x40
- 6 Counterbattens
- 7 Rafters

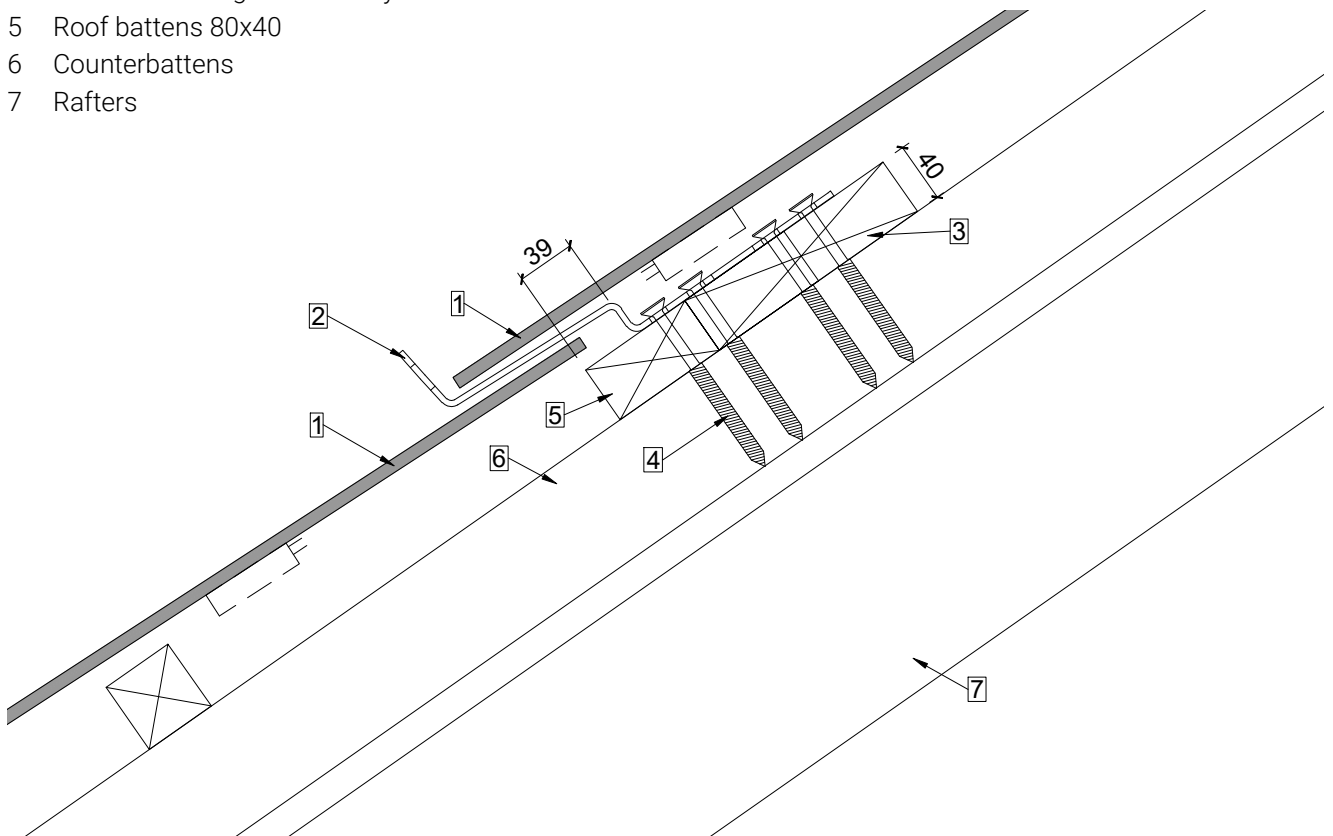

	<p><b>The separate and supplied assembly and instruction documents must be studied before assembly and must be followed exactly. The instructions must be read and understood by the users. The manufacturer's instructions must be strictly observed. Non-observance may result in personal injury.</b></p> <p><b>This sheet is not an assembly instruction!</b></p>
--	-----------------------------------------------------------------------------------------------------------------------------------------------------------------------------------------------------------------------------------------------------------------------------------------------------------------------------------------------------------------------

- It is mandatory to follow the official LEVEL & MATCH Slate safety hook notes and assembly instructions.
- It is recommended to place the safety hook in the ridge row.
- Safety hooks in the module field: Insert the module before mounting the next hooks above.
- The layout must be carried out by qualified personnel in accordance with the applicable local regulations.

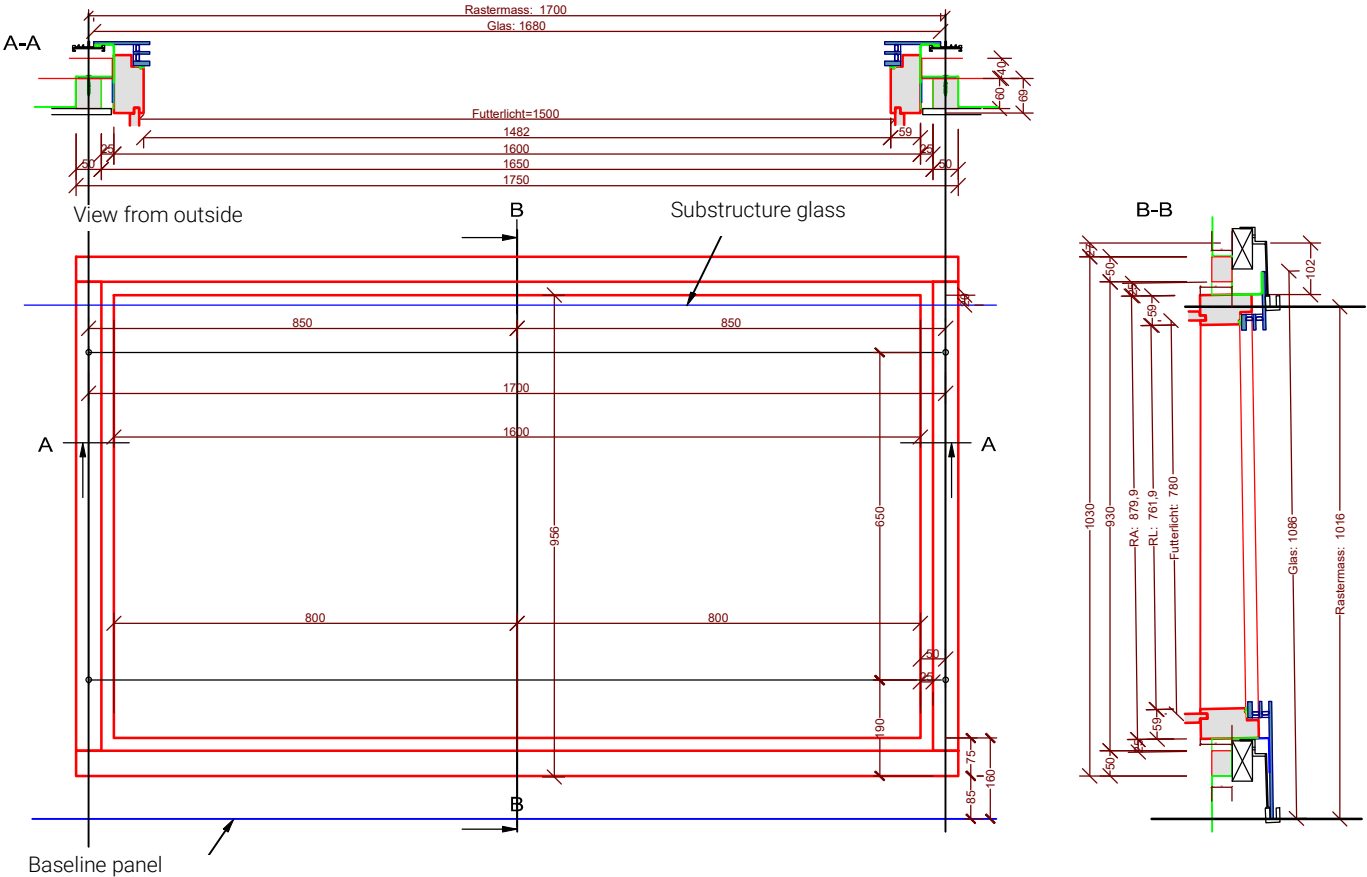

**Note the position of the junction box!**

- 1 LEVEL module
- 2 LEVEL middle hooks
- 3 LEVEL side support
- 4 Roof battens 50x50
- 5 Counterbattens
- 6 Tub & Inlet plate
- 7 Subroof
- 8 Shuttering
- 9 Sealing profile (between side supports)

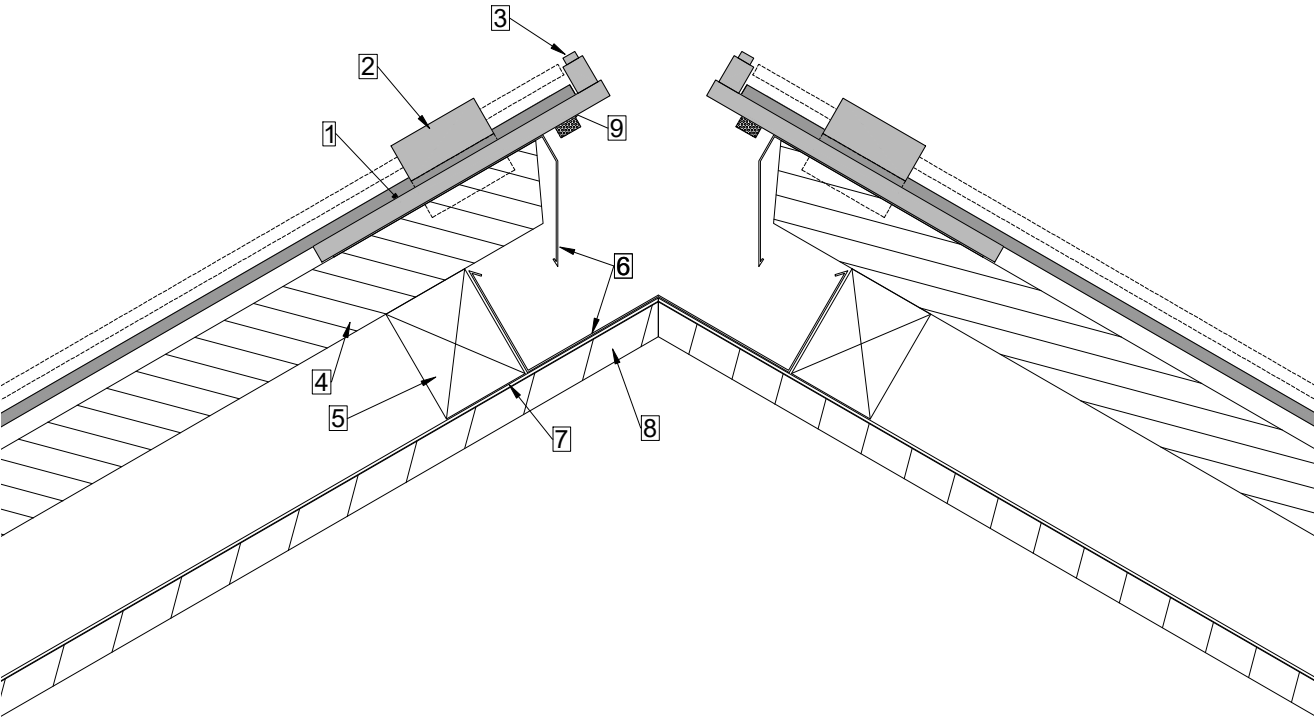
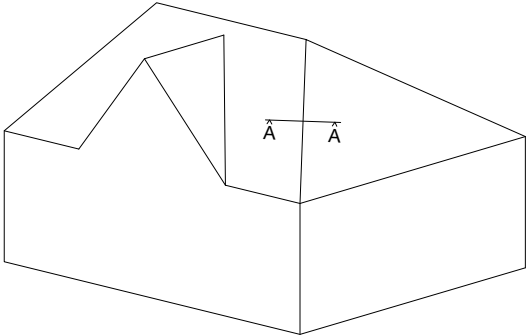

The installation situations shown serve as a suggested solution and orientation. Correct planning and execution must be adapted to local conditions and situations and is the responsibility of the contractor.

## Valley with tub

A4 | 1:5, 1:25 | V23.01 |

**Note the position of the junction box!**

- 1 LEVEL module
- 2 LEVEL middle hooks
- 3 LEVEL side support
- 4 Roof battens 50x50
- 5 Counterbattens
- 6 Tub
- 7 Subroof
- 8 Shuttering

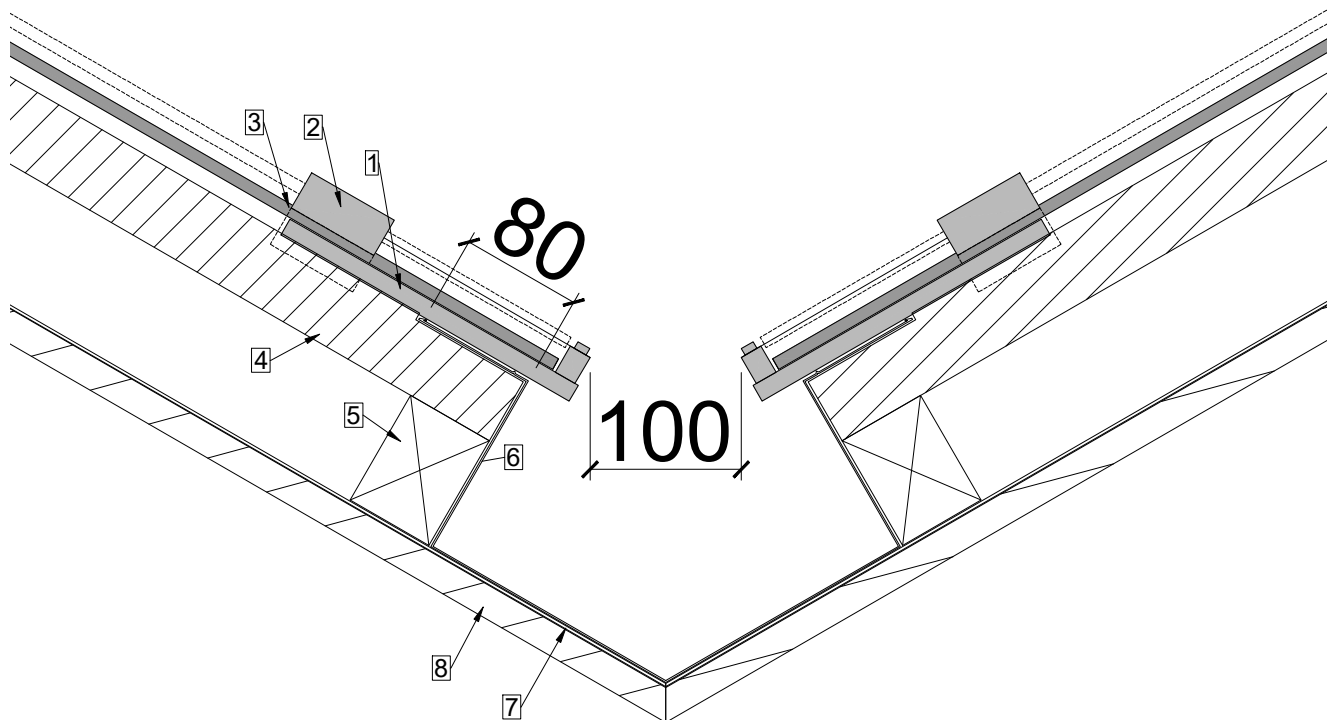
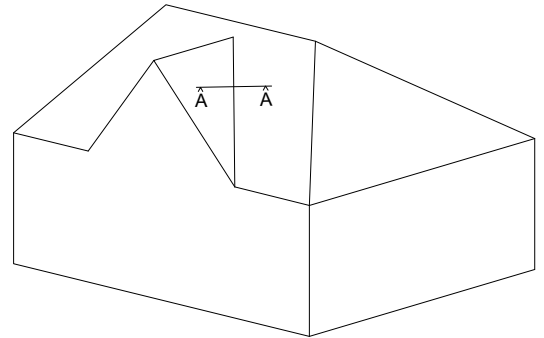

The installation situations shown serve as a suggested solution and orientation. Correct planning and execution must be adapted to local conditions and situations and is the responsibility of the contractor.

## Proposal tile connection

A4 | 1:5, 1:10 | V23.01 |

The LEVEL roof integrated system is generally recommended for full design. If customized modules are not possible, they can be replaced by aluminum composite plates. If LEVEL modules are required in the middle of a tile field, the system can be integrated with simple on-site measures.

- 1 LEVEL module
- 2 LEVEL middle hooks
- 3 LEVEL rail hooks
- 4 LEVEL rail
- 5 Aluminum angle
- 6 Schiftplättchen 4.5x25x60
- 7 sheet metal tinsmith

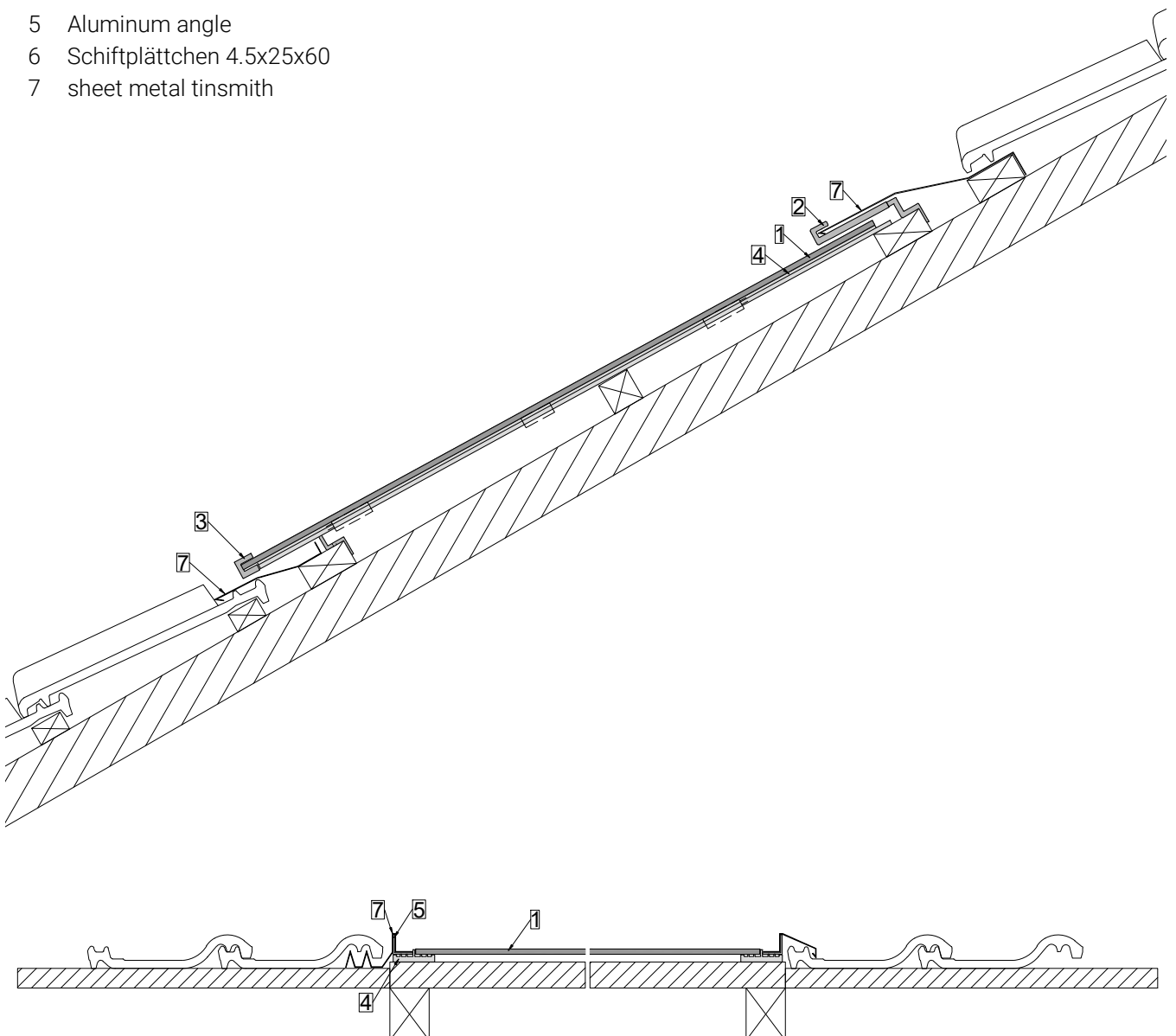

The installation situations shown serve as a suggested solution and orientation. Correct planning and execution must be adapted to local conditions and situations and is the responsibility of the contractor.