

Leading Architecture Integrated Photovoltaics

Designed Building Integrated Photovoltaics
Made in Switzerland



reddot winner 2021
urban design



RearCon Module Technology 19
NICER X Roof-integrated System 28

The logo for 'megasol' is located in the bottom right corner. It features the word 'megasol' in a lowercase, sans-serif font, with a stylized white sun icon to the right of the 'o'.

megasol



◀ Amt für Umwelt und Energie in Basel
Lighthouse project with exceptional feel

▲ Apartment building in Zurich
Solar facade with carbon-like appearance | Swiss Solar Prize Diploma 2019

Overview

Building-integrated photovoltaics

Impressions	4
It is surprising how harmoniously sustainable energy generation follows the lead of architecture. Technology has cast off adolescence and achieved maturity and flexibility.	
Design	11
New methods have enabled accents and nuances. Subtle playing with invisibility is achieved just as successfully as an uncompromising display of technology as a design element.	
Efficiency	16
The prescience of Perpetuum Mobile manifests itself in the building when integrated photovoltaics transform costs into returns.	
Safety	20
Integrated systems form the framework of the design. The top priorities are safety and adaptability.	
Cooperation	31
Individual consulting services are embedded into a project road map that ranges from a draft all the way to realisation and operation. The interfaces are open.	
Responsibility	32
Shaping the future comprises all areas of a living environment. In daily work, responsibility becomes the foundation of entrepreneurship.	
Company	35
The vision of one man has been inspiring and shaping the company for almost 30 years.	

Facade integration

Customized shapes **11** | Individual colours **12** | RearCon module technology **19**
FAST facade system **20** | NICER X integrated system **28** | Consulting services **31**



▲ Coop Letzipark Zurich | Solar facade with individually coloured modules



▲ Coop headquarters in Basel | FAST facade system

Photo: Aepli Metallbau AG

Roof integration

Border and special modules **11** | Designed appearance **12** | HiR cell technology **17**
MATCH Slate **22** | MATCH Tile **24** | LEVEL integrated system **26** | NICER X integrated system **28**



▲ Apartment building in Zurich | MATCH Tile integrated system



▲ Apartment building in Zurich | The LEVEL in-roof system anticipates the emerging patina of the copper roof in terms of color

Open structures



▲ Valley station Klein Matterhorn | 2'923 m.a.s.l. | Swiss Solar Prize 2018

Image: Solarbau Lowel GmbH



▲ Industrial Building in Arbon | Swiss Solar Prize 2017

Image: Solar Agentur Schweiz



Completed metamorphosis

Solar modules are concluding their development towards a freely designable building material. The design of this building material starts with the vision of the overall project. These steps lead from the central idea to the solar module.

1

The grid defines the shape, size and power of the solar modules

Rectangles, triangles, polygons, circles, curves, cut-outs: the free choice of the solar modules' geometries is the starting point for the design. The measurements range from 200 x 300 mm to 2400 x 4150 mm. Glass thicknesses of 2 - 12 mm per pane can be processed. Cost advantages are achieved by using the standard size of 1669 x 999 x 8 mm. The degree of hardening (TVG, ESG) can be chosen freely.

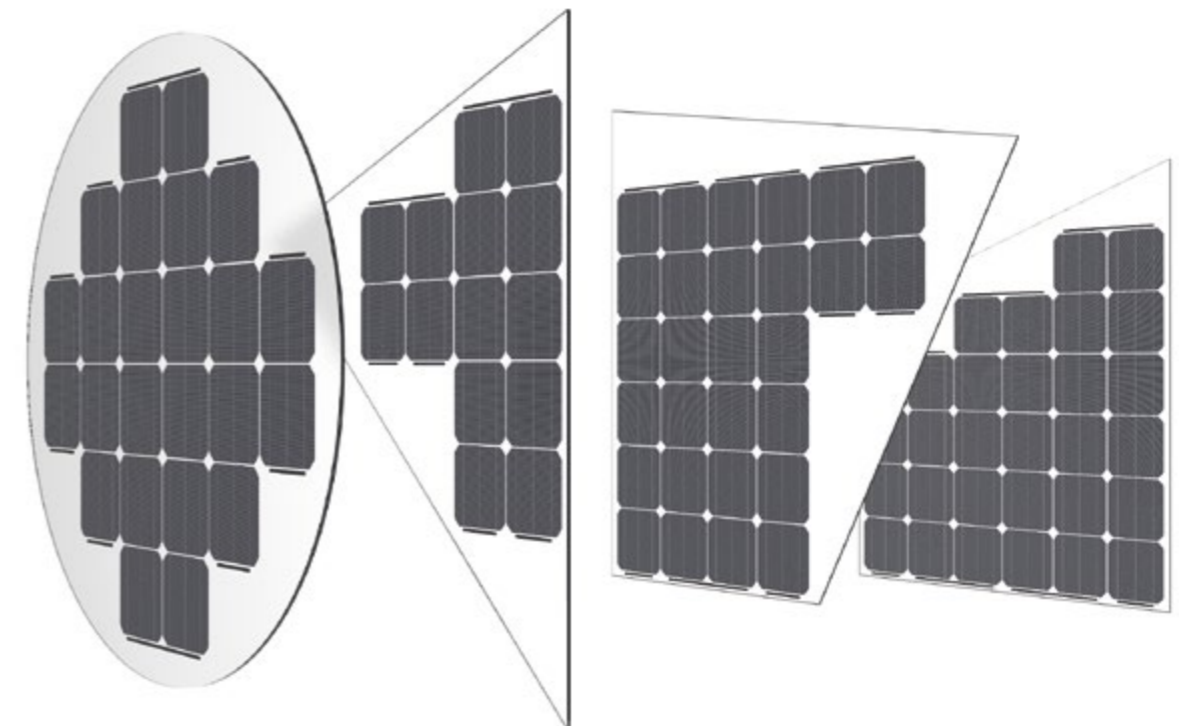

Special shapes

2 The appearance determines the surface of the solar modules

The full spectrum of the material «glass» is available for the design. Structures and finishes of surfaces are possible, along with the targeted use of reflections. The solar glasses «Fjord» and «Crystal» are the basis of most integrated solar modules, due to their subtle structuring and highest efficiency. This structuring ensures a high light transmission and minimal glare.

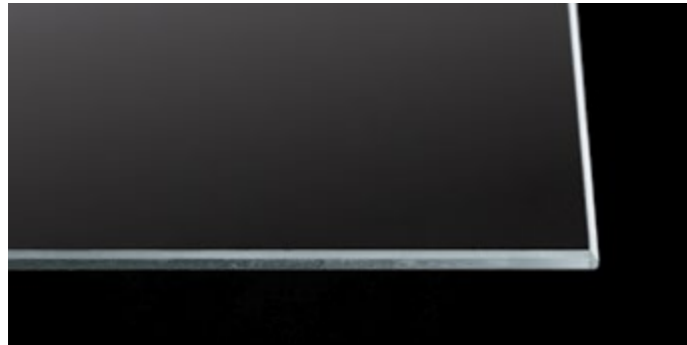

A Mountain Lake



B Frost



C Fjord



D Crystal



E Glacier

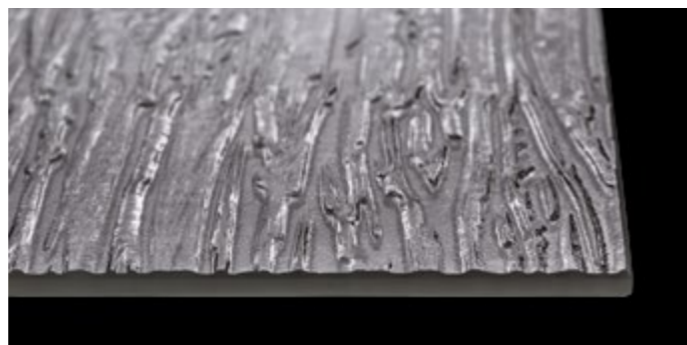

F Creek

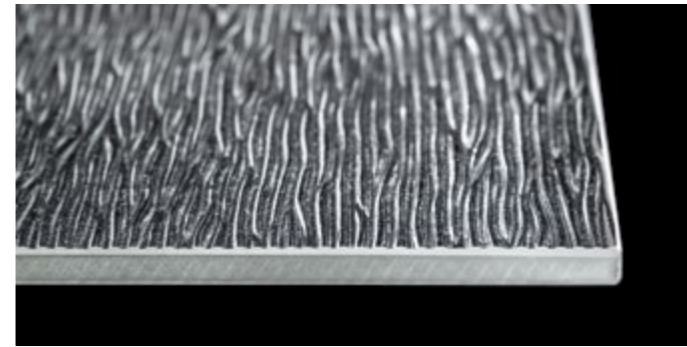

G Stream

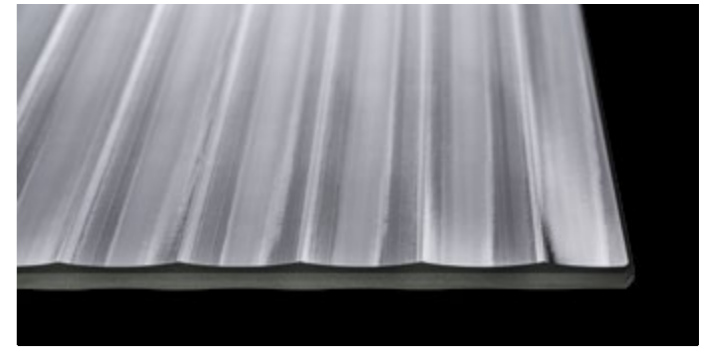

H Wave

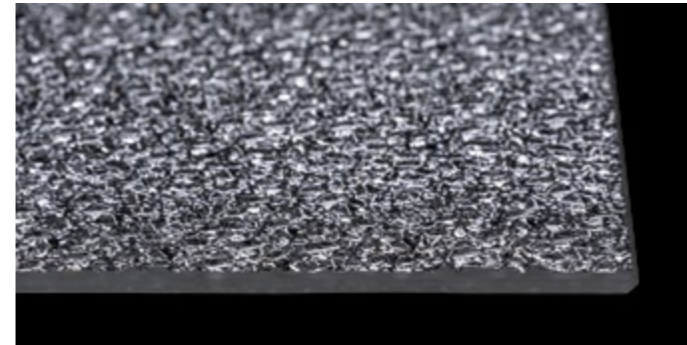

K Ice Diamond

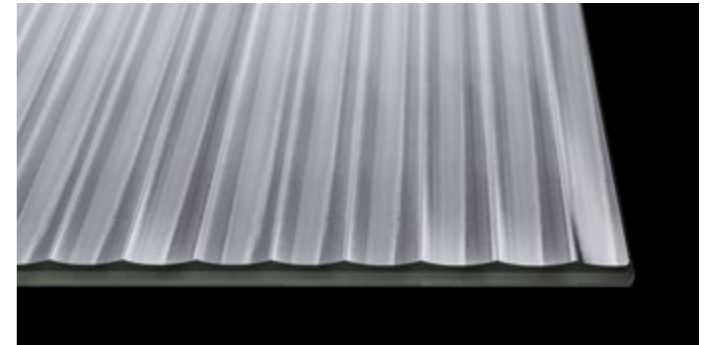

L Ripple



I Pearl (upon request)



M Snowdrift (upon request)

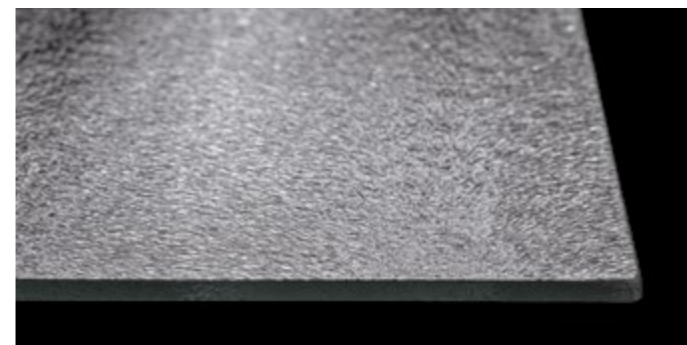

N Mistral (upon request)

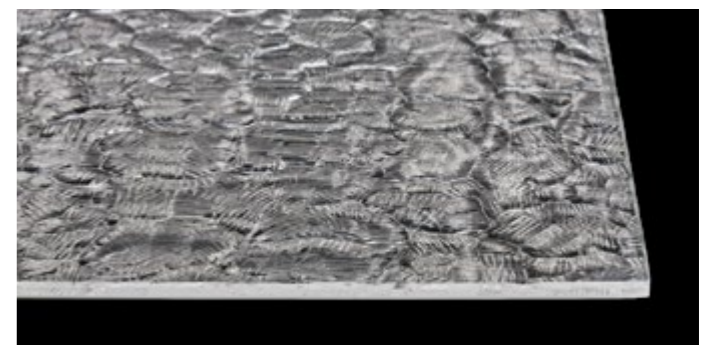

O Seaside (upon request)



solarcolor.ch/glass-finder

3

The character results from the colours and their intensity

Fine Line: The classical pinstriped look allows accents with the help of technology. This design option is the most efficient both in terms of performance and costs.

Totally Black: By moving the busbars (cell contacts) to the backside, discretion can be increased, so that the technology is only visible at second glance.

Translucent: Solar modules with translucent cell spacing for open structures. The degree of light transmission and output performance can be balanced by adapting the cell spacing.

Fine Art: The colour of the solar modules is open. It is possible to design with light pastel tones, as well as with rich earthy tones. Three sources can be used for the choice of colour:

- > SOLARCOLOR colour chart (time and cost-efficient)
- > NCS colour chart (wide colour spectrum)
- > Individual colour development (completely open)

High colour intensities (opacity) make the cell structure disappear, keeping the solar secret of the building envelope. Light intensities, on the other hand, allow a technoid impression and performance up to 95% of a conventional solar module (up to 200 Wp/m²).

On solarcolor.ch, it is possible to create and order individual samples. The following color charts are also available on solarcolor.ch.



SOLARCOLOR «Spring»



SOLARCOLOR «Summer»



SOLARCOLOR «Autumn»



SOLARCOLOR «Winter»



Fine Line Design

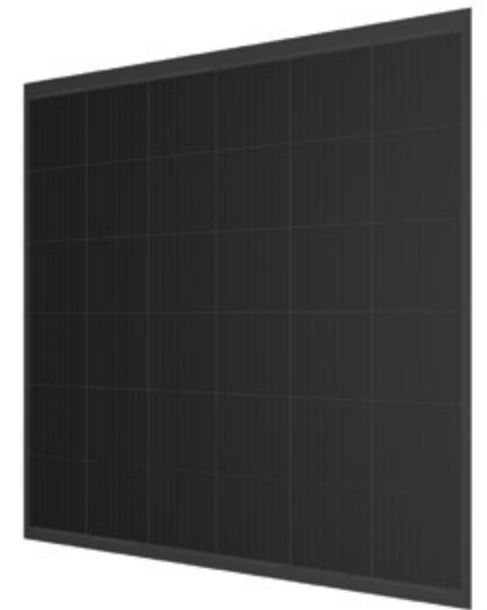

Totally Black Design

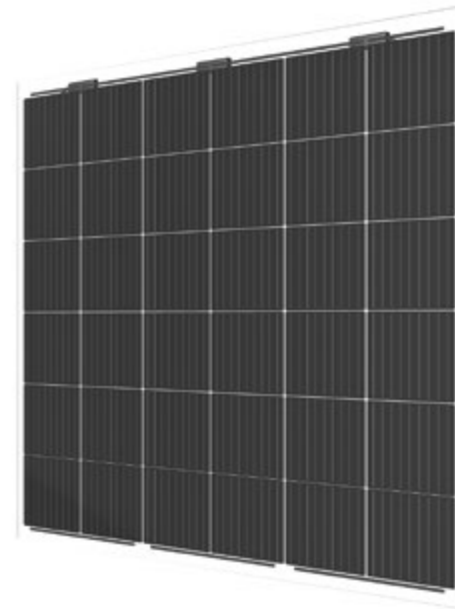

Translucent Design



Fine Art Design



solarcolor.ch/colorfinder

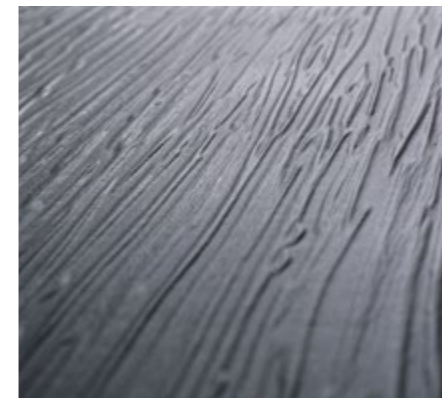

«Creek Granite Grey» with ZeroReflect

Upgrade ZeroReflect

The acceptance of solar installations among the population is very high. It is reinforced constantly with new types of designs and unrestricted individualisation options. ZeroReflect is a surface developed in the Megasol design laboratory that is glare- and reflection-free – regardless of the installation situation, angle or time of day.

It is used for particularly high demands in terms of «glare-free» solar modules. These include special installation situations, sensitive, subjective perception or regulatory restrictions (e.g. traffic junctions).

From costs to yields

Solar integrations are profitable investments. The reasons for this are, firstly, that the additional investments compared to conventional building envelopes represent a fraction of the total project costs. Secondly, solar building envelopes generate yields and amortise within a few years. In the period after that, they generate earnings and become profitable power plants. Two examples.

Example 1

Single-family home in Basel-City CH, Roof covering energetic roof renovation with LEVEL (10 kWp)

Costs for 60m ² roof area	Tiled roof	Solar roof	
Construction site equipment (scaffolding, lifting equipment, etc.)	4'500 CHF	4'500 CHF	
Insulation and sub-roof	10'500 CHF	10'500 CHF	
Roofing material	2'400 CHF	13'600 CHF	
Roofing labour	3'000 CHF	3'000 CHF	
Electrical installation	0 CHF	5'400 CHF	
Planning & project management	4'000 CHF	5'500 CHF	
Subsidies	- 3'000 CHF	- 10'500 CHF	
Tax benefit	- 4'700 CHF	- 7'100 CHF	Difference
Net investment	16'700 CHF	24'900 CHF	+ 8'200 CHF
Net revenue over 40 years	0 CHF	+ 60'000 CHF	+ 60'000 CHF

Example 2

Office building in Basel-City CH, facade renovation with FAST (116 kWp)

Costs for 1'400m ² facade area (window share: 50%)	Ceramic facade	Solar facade	
Construction site equipment (scaffolding, lifting equipment, etc.)	20'000 CHF	20'000 CHF	
Curtain wall facade (insulated, installed, 700m ²)	280'000 CHF	336'000 CHF	
Windows (triple glazing, installed, 700m ²)	238'000 CHF	238'000 CHF	
Electrical installation	0 CHF	28'000 CHF	
Planning & project management	30'000 CHF	38'000 CHF	
Subsidies			
Subsidy for energy-efficient facade renovation	- 84'000 CHF	- 84'000 CHF	
PV subsidy: One-off remuneration	- 0 CHF	- 37'000 CHF	
PV subsidy: «Inclination angle bonus»	- 0 CHF	- 29'000 CHF	Difference
Net investment	484'000 CHF	510'000 CHF	+ 26'000 CHF
Net revenue over 40 years	0 CHF	+ 348'000 CHF	+ 348'000 CHF

HiR cell technology

Highest cell efficiency and lifetime thanks to 0% PID & LID

The new proprietary cell technology

HiR (pronounced like the word «higher») is a proprietary cell technology from Megasol. HiR is based on n-type wafers, which for decades have proven to be the highest quality and most stable technology. The n-type HiR technology combines charge carrier selective contacts, so-called ultra-thin tunnel oxides (SiO₂), with a sophisticated multi-stack metallization and a multi-level anti-reflective coating.

The most power-stable modules in the world

n-type HiR solar modules have a much higher power stability compared to conventional PERC modules. n-type HiR modules have a significantly lower power degradation and are completely PID- and LID-free due to their design. This results from the fact that n-type HiR is completely insensitive to boron-oxygen complexes responsible for PID.

In the market, PERC modules with 4-5% power degradation due to PID or LID are also considered «PID-free». However, a 4-5% difference in yield can have a massive impact on the economic profitability of solar plants. n-type HiR modules have 0% PID and 0% LID and are thus the most power-stable modules in the world.

Better economic profitability and higher project yields

- > n-type HiR modules have a very high power output combined with very compact dimensions. More yield per roof area leads to higher economic efficiency and better project yields.
- > An optimal thermal coefficient and better low-light performance lead to more yield per kWp.
- > All HiR modules are bifacial and have a significantly higher bifaciality factor compared to conventional bifacial solar modules (over 90% instead of 70-75%).
- > Considerably lower proportion of grey energy

How it works: simply explained

The ultra-thin tunnel oxide layer reduces recombination losses and thus significantly increases efficiency. The very fine front and rear contact grids guarantee ideal electrical current absorption capability with good solderability and conductivity thanks to their layers that have each been optimised for their respective characteristics. Thanks to the anti-reflective coating, which is not only classically single-layered but multi-layered, the reflection losses on the cell surface are minimised. At the same time, the cell surface appears darker (black), which makes it even more attractive for projects with high aesthetic requirements.

Longer service life and longer warranty periods

- > Glass-glass modules are extremely durable and come with a 15-year Swiss product warranty and a 30-year linear performance warranty.
- > Best wattage prices per warranty year

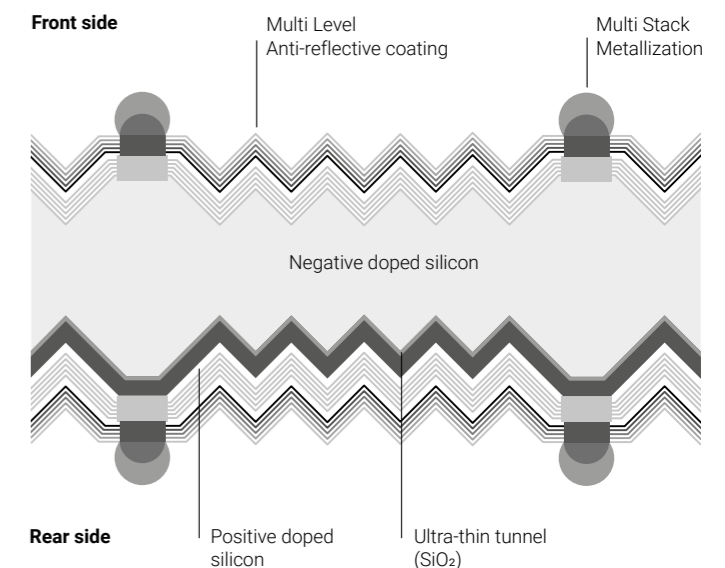

Glass-glass solar modules

Two glass panes are combined into one solar module. They become laminated safety glass and therefore have unique properties.

Areas of application

Applications include facades, railings, in-roof and on-roof applications, infrastructure structures (for example, dams, noise barriers, etc.), open spaces, carports, alpine and desert applications.

Properties

Front and back glass in combination with durable encapsulation material protect the components from vapour penetration. In the «neutral zone» between the panes, the cells remain stress-free (no compression or bending) which reduces the occurrence of so-called micro cracks. This results in a potential lifespan of over 50 years.

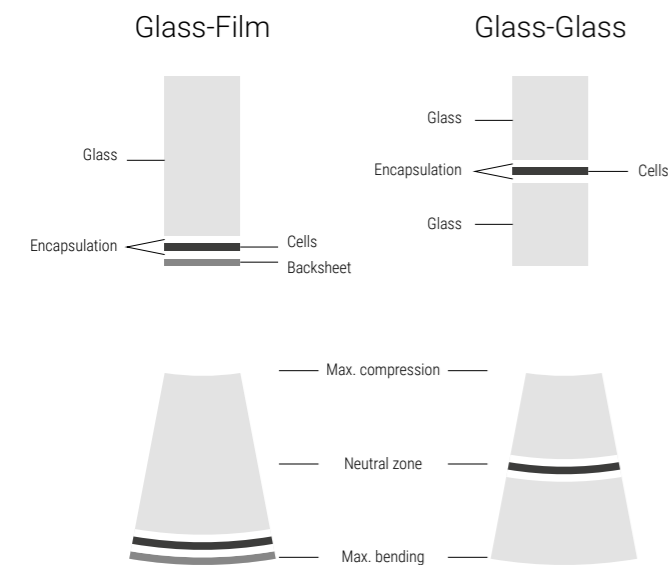

Free design scope, high durability and stability characterise this solar building material. All glass-glass modules can be designed freely. Glass-glass modules are manufactured in Deitingen, Switzerland.

Type of installation

Glass-glass solar modules can be installed both with or without frames. The mounting systems FAST, MATCH, LEVEL, NICER, LOCKUP, LOCKIN, LAYUP and LAYIN are especially suitable for the integration of glass-glass solar modules.

Non-glare solar glass

Particularly anti-glare surface structures are used.

Technical specifications

Megasol Cell technologies: Mono HiR / Mono HiR RearCon

Cell sizes: 156.75 mm (M2) / 158.75 mm (G1) / 166 mm (M6) / 182 mm (M10) / 210 mm (G12)

Cell geometries: Full-square, Half-cut, Triple-cut, Custom

Typical power (Full Black)*: 184-232 Wp/m²

Typical power (colour)*: 150-200 Wp/m²

Encapsulation material: EVA or PVB

Glass thickness per pane: 2-12 mm

Hail protection: Protection class 5 (hailstone size 50 mm)

Fire safety classification: B - s1, d0 according to European fire protection standard EN 13501-1. The building element is considered non-combustible material in terms of cantonal fire insurance.

* The square-metre performance of the module depends on the specific format.

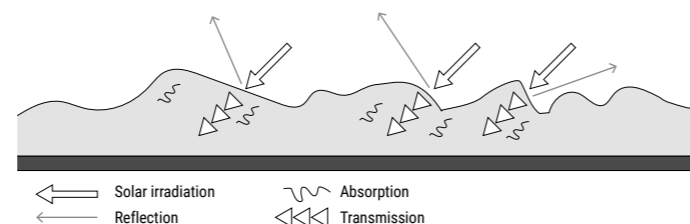

RearCon module technology

Elegant, deep black design, free of visible contacts, 23.2% cell efficiency and 5 world records

Contacts on the rear side

RearCon means «Rear Contact». All contacting that was previously visible has been moved from the front to the back. This technology is a game changer in terms of performance, price, durability and aesthetics.

23.2%: World record in the royal discipline of module efficiency

RearCon solar modules achieve module efficiencies of up to 23.2%. This corresponds to the world record for the most efficient commercially manufactured solar module. RearCon's performance improvements are achieved through the following technological innovations:

- > The elimination of front contacting leads to more active cell area and thus higher efficiency
- > Busbars with particularly high conductivity reduce internal resistances (lower ohmic losses)
- > Gapless modules: Cell spacing of -0.3 mm (instead of conventional +2.0 mm) leads to area savings and higher efficiency

Solar modules without cell spacing

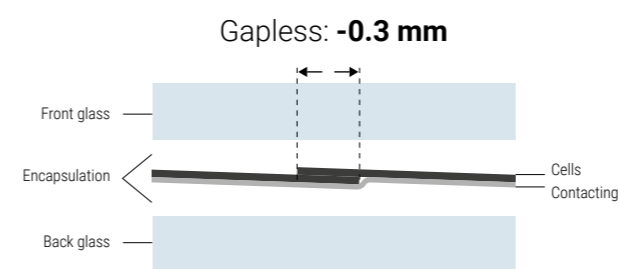

Solar modules with cell spacing

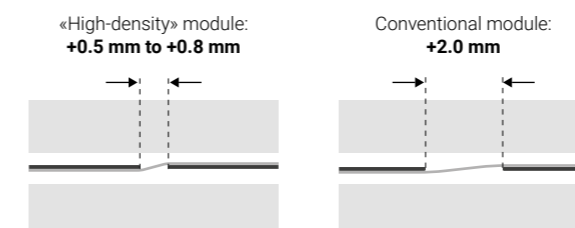

Design and aesthetic integration

The innovations in the area of aesthetics include these key points:

- > The contacts on the front side («pinstripe look») are completely eliminated
- > RearCon modules have black, homogeneous «Totally Black» surfaces
- > The cells overlap slightly («gapless») – the classic «square structure» is avoided

Price superiority

Due to the technology, the production costs for RearCon are considerably lower. RearCon technology requires a significantly lower number of production steps than the production of previously known rear-contacted solar modules. This cost advantage is passed on. RearCon solar modules are therefore at a significantly lower price level than previous rear-contacted solar modules.

Additional world records

RearCon reaches the top of the podium in five other disciplines. The five world records are particularly important in the field of individual solar building envelopes:

- > Most compact «400+ Wp» solar module
- > Most efficient full black solar module (full black surface)
- > Most efficient double-glass solar module (front and rear glass)
- > Most efficient bifacial solar module (power yields from front and rear side)
- > Most efficient 1'500V solar module (advantage especially for large scale projects)

FAST facade system

Substitution of all conventional facade elements with the most efficient solar facade in the world.

Areas of application

FAST is suitable for all areas where curtain wall systems are used. These include, for example, single-family homes, apartment buildings and high-rise buildings. Floor-high solar modules can be inserted into the FAST mounting system. It is used for particularly high static and aesthetic requirements.

How it works

The solar modules with backrails are placed into the horizontal profiles and folded up like a tilting window. They are fixed by a slide safety catch. Later dismantling is possible without restrictions.

Flexibility

Glass-glass modules used on the facade are usually custom made. Their shape, colour, size and surface can be individually designed. Price advantages can be achieved when using the standard measurements. Notes on the design process can be found on p. 31.

Compatibility

The FAST facade system is compatible with vertical structures in all standard materials (wood, aluminium, steel).

System interface

The adhesion of the backrails on the rear side of the module takes place in-house. This reduces technical, administrative and logistical interfaces as well as expenses.

Type of installation

The mounting is concealed by means of backrails on the rear side.

Installation time

10 m² / man-hour (experienced installation personnel)

Components

- > Glass-glass solar modules with SSG adhered backrails and mechanical support
- > Horizontal rail, slide safety catch
- > Vertical structure as well as consoles/spacer screws are often provided on site. If required, they are part of the package.

Technical specifications

Solar module type: glass-glass (colours, shapes, thicknesses, surfaces can be freely defined)

Vertical adjustment: +/- 4 mm, on the front also possible after mounting

Typical span width of the horizontal profile: 800 mm

Hail protection: Protection class 5 (hailstone size 50 mm)

Fire safety classification: B - s1, d0 according to European fire protection standard EN 13501-1. The construction is made of aluminum. The building element is considered non-combustible material in terms of cantonal fire insurance.

Vertical support: mechanical (lower edge of solar module)

Mounting procedure and options

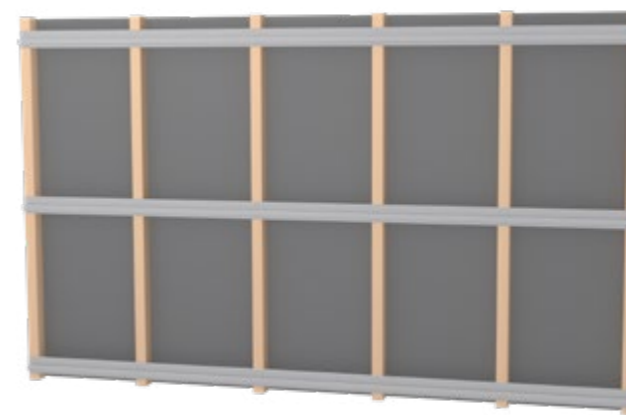

1 Apply transverse profiles to the vertical structure of the building.



2 Place module, inclination is possible for cabling.

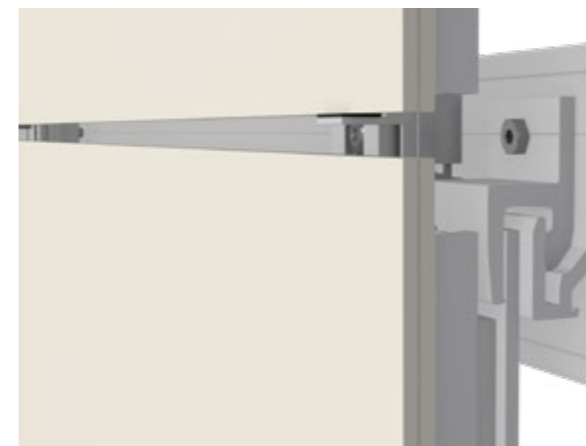

3 Secure module temporarily and adjust, +/- 4mm also possible after mounting.

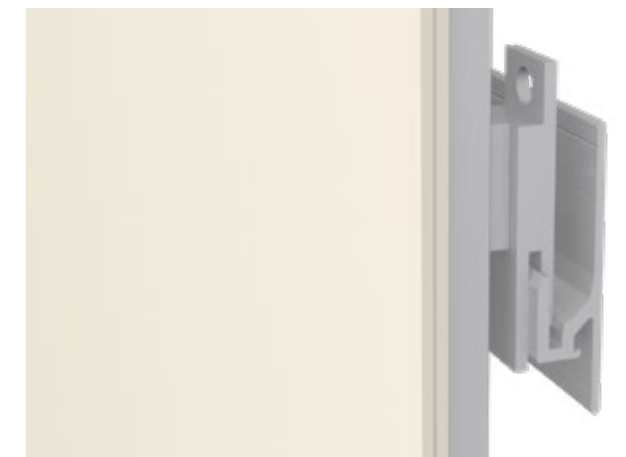

4 Secure and adjust the module provisionally



Option: Concealed mounting



Storey-high modules feasible without problems



Video and technical documentation:
megasol.ch/en/fast

MATCH Slate



reddot winner 2021
urban design

Complete roof covering or in combination with shingle-like roof coverings.

Areas of application

MATCH Slate is predestined for roof-integrated systems with high aesthetic demands – especially for projects where the design of the roof is based on a classic shingle look and/or demanding roof geometries exist.

How it works

The system is built on a conventional roof battening. The solar modules are fixed to the roof with discreet MATCH hooks and form a seamless transition to the roof edges, whereby no on-site metal sheeting work is required. MATCH Slate can also be perfectly integrated into an existing shingle roof covering (e.g. aluminium composite panels, fibre cement, glass elements, etc.)

Flexibility

Intelligently designed standard formats give the system a high degree of flexibility. Customer-specific sizes can be produced. The formats can be combined in any way in different installation layouts and thus give the roof an unmistakable character.

Installation type and time

MATCH Slate is used just like classic roof shingles. The installation time is also based on this.

Design

MATCH Slate is available with the standard designs Fjord Full Black, Creek Totally Black, Creek Brown and Creek Granite Grey.

Individual colours and glass surfaces can be freely designed according to SOLARCOLOR (solarcolor.ch). Design options are illustrated on pages 12 - 15.

Components

- > MATCH Slate module
- > MATCH Slate hook and stopper
- > *Anchoring device for personnel protection (optional)*

Sub-roof requirements

- > Roof pitch above 25°: sub-roof for normal demands
- > 14° - 25°: for increased demands
- > 6° - 13°: for extraordinary demands
- > 3° - 5°: with flat roof quality

Technical specifications

Solar module type: glass-glass modules

Hail protection: Protection class 5 (hailstone size 50 mm)

Fire safety: The top cover layer and the back side are made of heat-resistant glass. The construction is made of aluminum. The construction element is considered non-combustible material in terms of cantonal fire insurance.

Rear ventilation: by means of wooden slats



1 Prepare roof battening

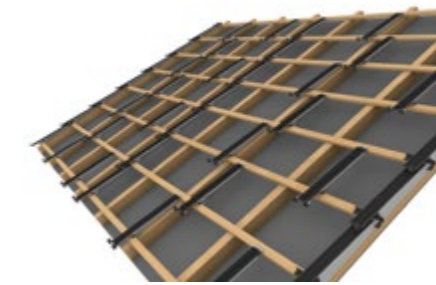

2 Install module hooks

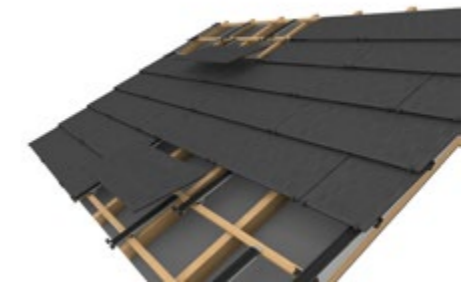

3 Insert MATCH Slate modules

Module formats



Cellular matrix: 2 x 2 cells
Grid dimensions: 407 x 380 mm



Cellular matrix: 2 x 6 cells
Grid dimensions: 1051 x 380 mm



Cellular matrix: 2 x 10 cells
Grid dimensions: 1694 x 380 mm

Examples of installation layouts

MATCH Slate can be freely combined with other individual installation layouts.

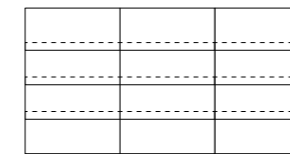

Normal 2 x 6

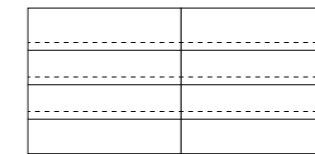

Normal 2 x 10

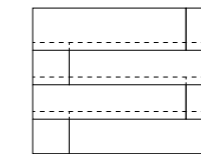

Offset 2 x 10 with 2 x 2

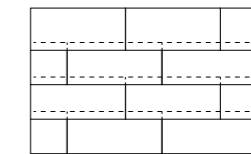

Offset 2 x 6 & 2 x 2

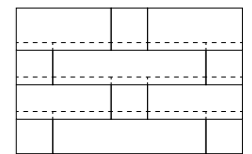

Combo 2 x 6 & 2 x 2 / 2 x 10

Standard designs

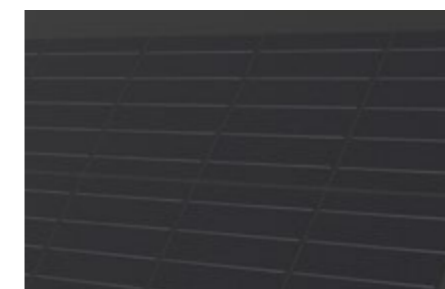

Fjord Full Black

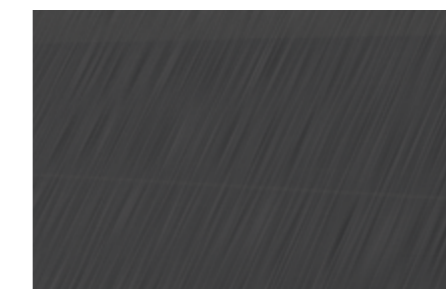

Creek Totally Black

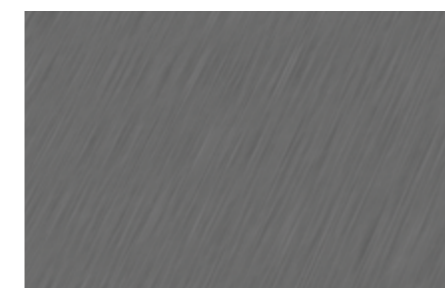

Creek Granite Grey

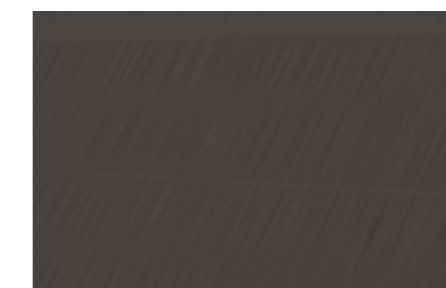

Creek Brown

Overhanging verge

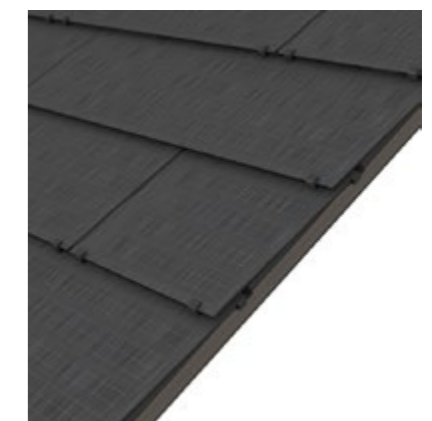

Complete integration without tinsmith work



Video and technical documentation:
megasol.ch/en/match/slate

MATCH Tile

Solar roof covering in combination with roof tiles.

Areas of application

MATCH Tile is predestined for roof-integrated systems with high aesthetic demands – especially for projects where the design of the roof is based on a classic tile look and/or demanding roof geometries exist.

How it works

The system is built on a conventional roof battening. The solar modules are fixed to the roof with discreet MATCH hooks and form a seamless transition to the roof tiles, whereby no on-site metal sheeting work is required.

Compatibility

MATCH Tile is compatible with the following roof tiles:

- > ZZ Wancor Plano
- > Swiss TL
- > Nelskamp G10
- > Erlus Scala
- > AGZ Ziegeleien AG GS37 Glattschiebeziegel
- > Jacobi Walther Z10
- > Creaton Cantus
- > Gasser FS03 & MS95

(other manufacturers/tiles on request)

Installation type and time

MATCH Tile is used just like classic roof tiles. The installation time is also based on this.

Design

MATCH Tile is available with the standard designs Fjord Full Black, Fjord Brown, Fjord Grey and Fjord Terracotta. Individual colours and glass surfaces can be freely designed according to SOLARCOLOR (solarcolor.ch). Design options are illustrated on pages 12 - 15.

Components

- > MATCH Tile module
- > MATCH Tile hook

Sub-roof requirements

- > Roof pitch above 25°: sub-roof for normal demands
- > 14° - 25°: for increased demands
- > 6° - 13°: for extraordinary demands
- > 3° - 5°: with flat roof quality

Technical specifications

Solar module type: glass-glass modules

Hail protection: Protection class 5 (hailstone size 50 mm)

Fire safety: The top cover layer and the back side are made of heat-resistant glass. The construction is made of aluminum. The construction element is considered non-combustible material in terms of cantonal fire insurance.

Rear ventilation: by means of wooden slats



1 Prepare roof battening



2 Install module hooks



3 Insert MATCH Tile modules

Module formats



Cellular matrix: 2 x 2 cells
Grid dimensions: 446 x 380 mm
(Module type **A2**, replaces 2 tiles)



Cellular matrix: 2 x 4 cells
Grid dimensions: 765 x 380 mm
(Module type **B3**, replaces 3 tiles)



Cellular matrix: 2 x 7 cells
Grid dimensions: 1230 x 380 mm
(Module type **C5**, replaces 5 tiles)



Cellular matrix: 2 x 5 cells
Grid dimensions: 892 x 380 mm
(Module type **A4**, replaces 4 tiles)



Cellular matrix: 2 x 9 cells
Grid dimensions: 1530 x 380 mm
(Module type **B6**, replaces 6 tiles)



Cellular matrix: 2 x 6 cells
Grid dimensions: 1060 x 380 mm
(Module type **D5/E4**, replaces 5/4 tiles)

Standard designs

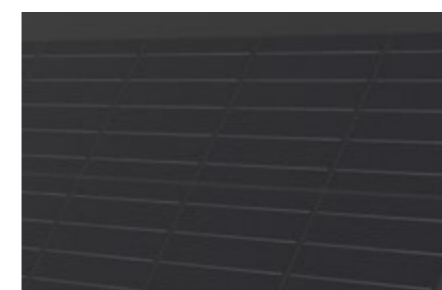

Fjord Full Black

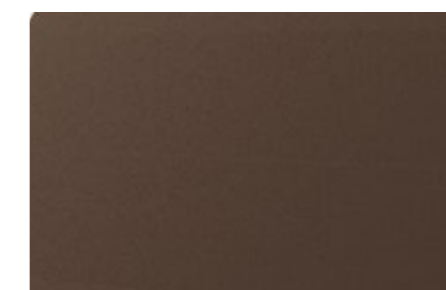

Fjord Brown

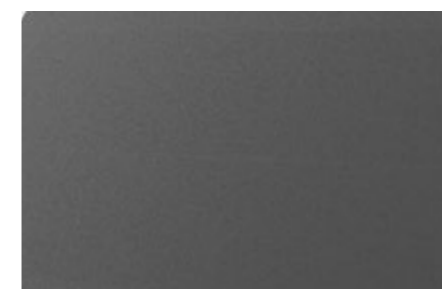

Fjord Grey



Fjord Terracotta

Installation layouts

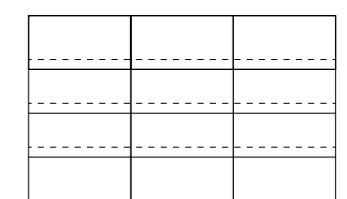

Normal

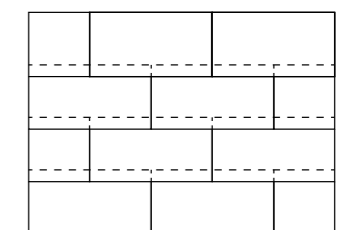

Offset



Video and technical documentation:
megasol.ch/en/match/tile

LEVEL roof-integrated system

Overlapping solar roofing for full-surface coverage.

Areas of application

LEVEL is used for pitched roofs, challenging roof geometries, individual roof integrations, as well as facades.

How it works

The holding hooks are screwed onto the roof battens. The sealing rails are fitted onto them. The solar modules are laid in. Later dismantling is possible without restrictions.

Flexibility

Half and quarter modules with identical appearance are among the standard components of the system. The basic palette contains three colour versions. More complex design requirements (colour, surface) can be realised with individually designed solar modules.

Compatibility

The LEVEL roof-integrated system can easily be combined with all standard roof coverings such as roof tiles, shingles or aluminium composite panels. A skylight (Wenger Fenster) specially developed for the LEVEL roof-integrated system enables seamless integration. LEVEL can be equipped with an integrated snow guard.

Type of installation

The system is laid overlapping, using the conventional or English method (horizontal offset).

Installation time

10 m² / man-hour (experienced installation personnel)

Components

- > LEVEL solar modules
- > Holding hooks
- > Sealing rails
- > *Snow guard (optional)*
- > *Wenger skylight (optional)*
- > *Anchoring devices for personal protection (optional)*

Sub-roof requirements

- > Roof pitch above 25°: sub-roof for normal demands
- > 14° - 25°: sub-roof for increased demands
- > 6° - 13°: sub-roof for extraordinary demands
- > 3° - 5°: sub-roof with flat roof quality

Technical specifications

Solar module type: frameless glass-glass modules

Grid dimensions: 1740 x 1060 mm

Hail protection: Protection class 5 (hailstone size 50 mm)

Fire safety: The top cover layer and the back side are made of heat-resistant glass. The construction is made of aluminum. The construction element is considered non-combustible material in terms of cantonal fire insurance.

Rear ventilation: by means of wooden slats

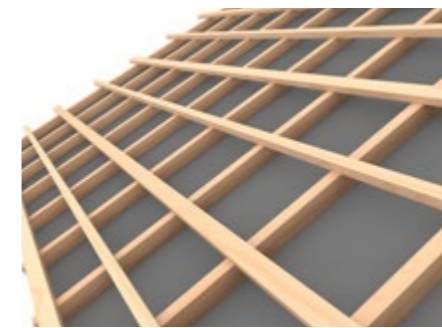

1 Roof battens 80 x 40 and 50 x 50 are fitted alternately in the grid.



2 The rail hooks are mounted directly on the roof battens.



3 The support rails can be pushed easily into the rail hooks.

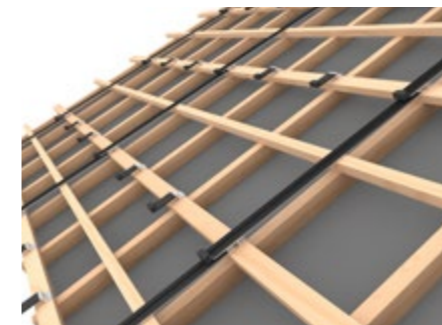

4 Central hooks provide additional stability.

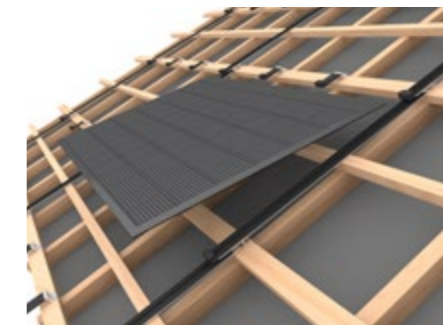

5 The solar modules can be pushed up from below and laid in.

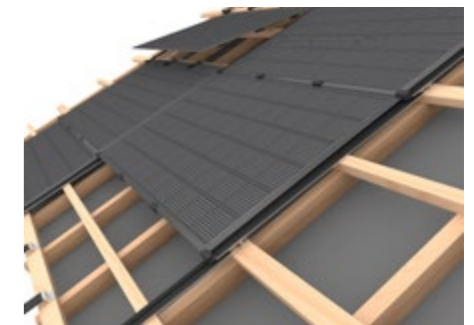

6 The roof-integrated system allows individual layouts.

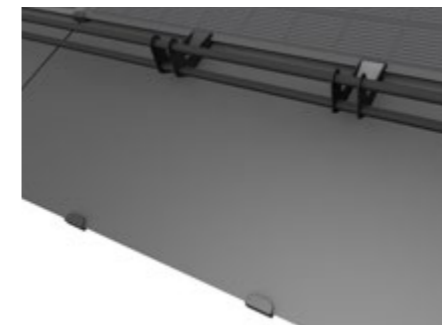

Option: Snow guard

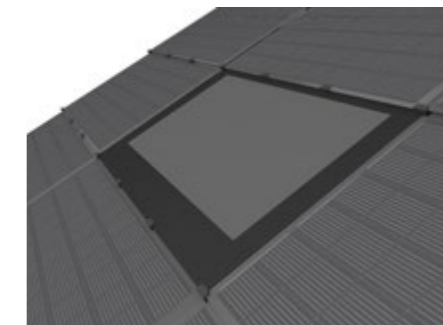

Option: Skylight

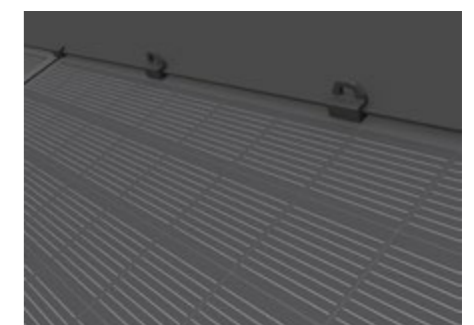

Option: Anchoring devices for personal protection

Basic modules

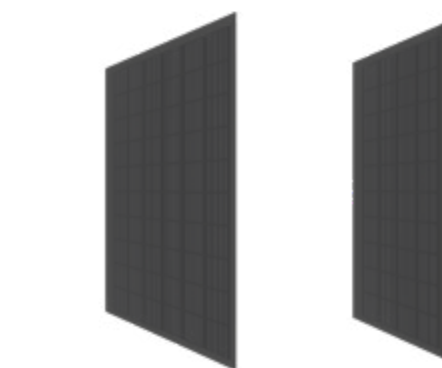

6 x 10 cells

4 x 10 cells

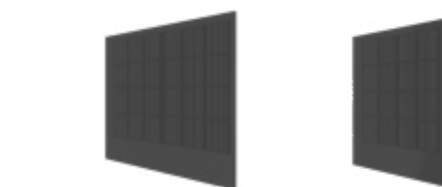

6 x 4 cells

4 x 4 cells

Colour variations

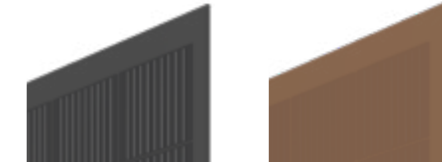

Full Black

Terracotta

Individual colours and glass surfaces can be freely designed according to SOLARCOLOR (solarcolor.ch). Design options are illustrated on pages 12 - 15.

Special solar modules

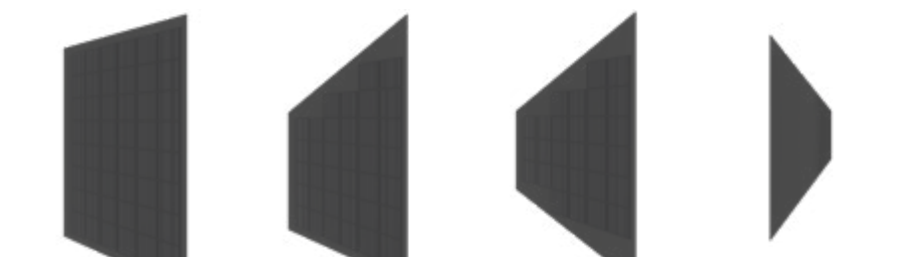

Category 1
Complexity: low
Adapted module length

Category 2
Complexity: medium
One side slanted, or
adapted module height

Category 3
Complexity: high
Various modifications,
two sides slanted,
cut-outs, round shapes,
holes

Category 4
Electrically passive
Complexity: high



Video and technical documentation:
megasol.ch/en/level



NICER roof-integrated system

Flush-mounted solar roofing with highest cost efficiency.

Areas of application

Typical areas of use for NICER are pitched roofs, roofings of any kind, wood and steel constructions. The most frequently used roof-integrated system in Switzerland is especially suitable for flat inclinations up to 3°.

How it works

Vertical supports are applied to the roofing battens. The modules are placed into the vertical supports and closed similarly to a car boot door. The modules are fixed with a snap lock. Later dismantling is possible without restrictions.

Flexibility

NICER solar modules are available as black, white and translucent versions. Half and quarter modules with a comparable appearance are among the standard components of the system. Translucent NICER systems are particularly suitable for carports, hangars, stadium roofs or pergolas and provide targeted shading and sun protection with simultaneous use of residual light.

Compatibility

A skylight (Wenger Fenster) specially developed for the NICER roof-integrated system enables seamless integration. NICER can be equipped with an integrated snow guard.

Note: NICER X is not compatible with previous NICER versions.

Type of installation

NICER modules are installed flush-mounted and floating (horizontally and vertically).

Installation time

20 m² / man-hour (experienced installation personnel)

Components

- > NICER solar modules
- > Vertical rail
- > Roof ridge profile
- > Covering panel and ventilation grid
- > *Snow guard (optional)*
- > *Wenger skylight (optional)*

Sub-roof requirements

Canopy, carport, open warehouse, etc.
(buildings that do not have to be completely water-proof in practice)

- > No sub-roof necessary

Residential buildings, office buildings, closed halls, etc.

- > Roof pitch above 13°: sub-roof for normal demands
- > 7° - 13°: sub-roof for increased demands
- > 3° - 6°: sub-roof for extraordinary demands
- > 0° - 3°: sub-roof with flat roof quality

Rail extensions and special modules can affect impermeability and must be verified individually.

Technical specifications

Solar module type: Glass-glass modules with frame

Grid dimensions: 1740 x 1060 mm

Fire safety: The top cover layer and the back side are made of heat-resistant glass. The construction is made of aluminum. The construction element is considered non-combustible material in terms of cantonal fire insurance.

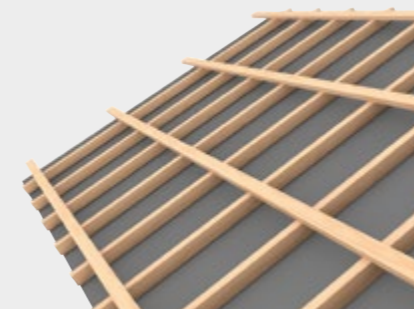

1 A steel or wood construction serves as the basis.



2 The NICER rails are laid out and screwed onto the roof battens.



3 The roof ridge profiles are then installed.

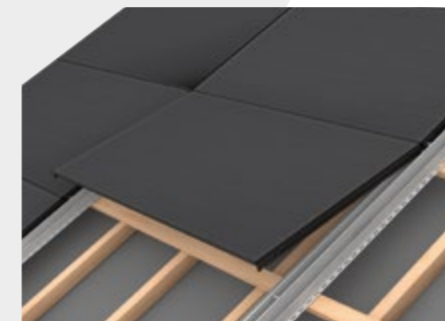

4 The individual solar modules can simply be clicked in...



5 ... and fastened.



6 Install the covering plate and ventilation grid.

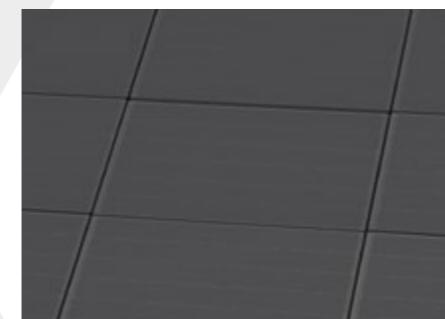

7 Completely installed, NICER is a water-proof roof covering.



Option: Snow guard

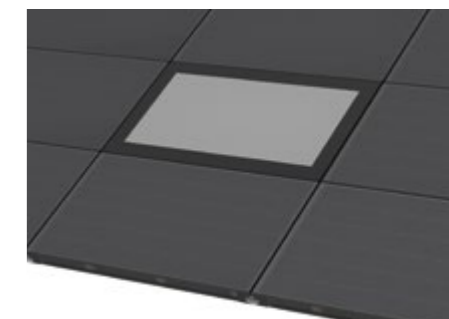

Option: Skylight

Colour variations



Black

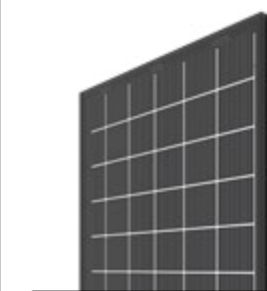

Translucent, increased cell spacing

Basic modules



6 x 10 cells

4 x 10 cells



6 x 5 cells

4 x 5 cells

NICER X – what's new.

Improved aesthetics

- > Totally Black is the standard design (no visible contacts thanks to RearCon module technology)
- > No visible EPDM components

New Snap-Lock mechanism

- > Visual feedback confirms that the solar modules are securely locked in place
- > The fastener can be opened and re-engaged several times

Compact system

- > Overall construction height of only 100 mm
- > Simplified handling
- > The 3 mm protruding frame protects the double-glass laminate during installation



Video and technical documentation:
megasol.ch/en/nicer



▲ Residential building in Savognin (Swiss Alps) | MATCH Slate Creek Grey

Expert consultation

Solar projects involve specific topics that required specific attention. A road map from the vision to implementation can contain the following milestones:

- 1 Gaining a shared understanding**
The focus is on the vision and the planned appearance of the overall project. The first technical approaches are outlined. Preferences regarding interfaces and consultation services are discussed.
- 2 In-depth introduction**
The doors of Megasol are open for partners. A production tour in Deitingen CH shows how the company works and where the integrated solar modules come from.
- 3 Rough concept**
Guiding ideas flow into a rough concept and are formalized as system principles. It is possible to make substantiated statements about investment and profitability. The first samples follow.
- 4 Detailed concept**
The design and the systems are worked out in detail and specified. Developments and formalities are carried out. Further samples follow and are approved.
- 5 Implementation**
The solar modules are manufactured according to the agreed plans and designs. Support is ensured during the building phase and operation.

- Services**
- Project support:**
- > Consulting / training
 - > Detailed design options
 - > Grid layout
 - > Connection details / interfaces
 - > String / inverter dimensioning
 - > After Sales
- Formalities:**
- > EIV, ESTI, EEA
- Development:**
- > Design / colour
 - > Samples / mock-ups
 - > Customized mounting solutions
 - > Integration of storage solutions, energy management, charging infrastructure for e-mobility

Values as a solid foundation

Responsible actions form the cornerstone of our company. The aim is to create opportunities for others and therefore give back some of the success.

Society

Social commitment

Megasol is committed to ecological and social sustainability projects in economically disadvantaged regions – for example Solafrica's *Solar Learning* initiative and the Women's Solar Project Nicaragua. The commitment includes material supplies for specific projects or financial support, which benefit local vocational training and build up competent young talent in the solar sector.

Manufacturing and research site

Forward-looking and regular investments in the production site in Deitingen as well as close cooperations with universities and technology partners set the relevant signals and help to strengthen Switzerland as a centre of research and industry.

Corporate culture

The corporate culture is based on a high degree of trust in the employees. Room for creativity and self-responsibility are the sources of its innovative strength and the continual development of the company. In China, the remuneration exceeds the local standard in terms of benefit-oriented promotion. All employees are provided with further training and language courses. The implementation of Swiss safety and health standards at both sites is a question of entrepreneurial conscience.

Environment

Material and manufacturing

From the sourcing of raw materials to the completed solar module, manufacturing almost exclusively uses renewable energies. In Deitingen, the electricity necessary for the production is produced on site by means of a solar plant. The applied high-performance solar cells consist of high-purity silicon – free of cadmium, rare earths and heavy metals or other problematic substances.

Recycling

The involvement with the Swiss foundation SENS and the European PV Cycle enables the reuse of almost 100% of the material used for Megasol solar modules.

Electromobility

An own fleet of electric vehicles and free solar charging stations at the Deitingen production site reinforces the investment in future-orientated environmental technologies.

Quality

Certifications

The manufacturing processes are TÜV-tested and run in accordance with EN/IEC and ANSI/UL standards.

Traceability

Based on the individual serial number, all materials used for each solar module can be traced back to the raw material batch without any gaps.

Testing steps

Each individual solar module undergoes a multitude of test steps. These include electroluminescence tests, flash tests and visual controls. The company has its own test centre. Tests such as Damp Heat, Shockfreeze, UV Lifetime, Dynamic Load, Thermocycle and Overpressure ensure the durability of the solar modules.

Awards

Every year, the market research institute EUPD Research identifies the most successful and strongest brands on the PV market. For the installers surveyed, Megasol ranks consistently among the most popular module manufacturers.

Megasol is an award-winning company. Many Swiss and European solar prizes and architectural awards testify to the trust that is placed in Megasol.

Politics

Involvement

Despite enormous potential, photovoltaics require strong voices in politics. Through memberships in industry associations and interest groups, Megasol is involved in sustainable progress. The focus in everyday life is on concrete steps: appearances at conferences, provision of comprehensive information material for voting and guided tours for schools and political parties – also for those who are traditionally critical of environmental issues.





Vision and vigour

Founder

Markus Gisler founded Megasol in 1993 in his youth. He directs the company as CEO and president of the administrative board. His vision led to the organic and continual development of Megasol Energy Ltd. The vision remains the driving force in everyday company life.



Markus Gisler, Founder and CEO

Vision

Solar modules by Megasol are intended as design material from which structures and pictures can be created. The integration of solar technology not only into buildings, but also into the living environment and consciousness of people, is the maxim.

Locations

The company consistently focuses on two locations. Development, administration and production are anchored in Deitingen, Switzerland. With a strong focus on customer proximity, individual design requirements can be met. Our factory in Ningbo, China, is specialized in large series and standard solutions.

Partnerships

The company has a wide network of architects, planning offices, investors, installers and operators. The company also fosters close partnerships with universities and both national and international research institutes.

Megasol Energy Ltd.

Industriestrasse 3
CH-4543 Deitingen

+41 62 919 90 90
info@megasol.ch
www.megasol.ch

© Megasol Energy Ltd.

BIPV-EN-V5

Subject to errors and technical modifications

▼ Cleantech Businesspark in Deitingen

